



SINGLE-DECK MERCHANDISER

INSTALLATION & OPERATIONS MANUAL

WARNING / FOR YOUR SAFETY

Do not store or use gasoline or other flammable vapors and liquids in the vicinity of this or any other appliance.

WARNING

R290 flammable refrigerant in use. Improper installation, adjustment, alteration, service or maintenance can cause property damage, injury or death. Read the installation, operating and maintenance instructions thoroughly before installing or servicing this equipment.

MIDA

3'x3', 4'x4', 4'x8'

Table of Contents

Introduction	ii	Airflow and Defrost	12
Technical Data.....	2-3	Case Cleaning.....	13-15
General Description	4	Troubleshooting.....	16
Transport and Handling	4	Safety Devices & Service.....	17-18
Positioning and Installation	5-7	Parts Ordering.....	19-33
Case Connection.....	8-10	Appendix & Wiring Diagrams.....	34-41
Pre-Power Check List	11	Warranty.....	43

To ensure proper functionality and optimum performance, it is **STRONGLY** recommended that Hillphoenix cases be installed/serviced by qualified technicians who have experience working with commercial refrigerated display merchandisers and storage cabinets. For a list of Hillphoenix-authorized installation/service contractors, please visit our website at www.hillphoenix.com.

Hillphoenix®

A DOVER™ COMPANY

P114309K
V.1 R.0
04/2020



Important

At Hillphoenix®, the safety of our customers and employees, as well as the ongoing performance of our products, are top priorities. To that end, we include important warning messages in all Hillphoenix installation and operations handbooks, accompanied by an alert symbol paired with the word "DANGER", "WARNING", or "CAUTION".

All warning messages will inform you of the potential hazard; how to reduce the risk of case damage, personal injury or death; and what may happen if the instructions are not properly followed.

This manual must be stored near the display case where it can be easily consulted. If this manual does not provide the information you require please contact Hillphoenix for more information.

 DANGER
Indicates a potential safety risk for refrigerated case users and/or the refrigerated case itself , the possible consequences being damage to the case and/or serious injury to workers.
 NOTE
Draws attention to important details that personnel must be aware of and always keep in mind to ensure proper use and operation of the refrigerated case.
 FORBIDDEN
Draws attention to tasks that are absolutely forbidden ; failure to observe this warning can cause damage to the refrigerated case and/or injury to workers. Hillphoenix will not be held liable per damage to things and/or injury to persons caused by failure to observe such warnings.

Revision History

SYSTEM REQUIREMENTS						
Case Size	Volts	Phase	Electrical Circuits Per Case	Total Amps	MCA	MOP
3' x 3'	120	1	1	3.6	4.37	15A
4' x 4'	120	1	1	8.6	10.96	15A
4' x 8'	120	1	1	17.9	20.4	25A
4' x 8'	120	1	(2 (1 OF 2))*	9.7	12.1	15A
4' x 8'	120	1	(2 (2 OF 2))*	8.2	10.3	15A

ELECTRICAL DATA					
Case Size	Fans Per Case	High Efficiency Fans		Anti-Condensate Heat	
		120 Volts		120 Volts	
		Amps	Watts	Amps	Watts
3' x 3'	1	0.02	3.0	0.40	48.0
4' x 4'	2	0.05	7.0	1.03	123.0
4' x 8'	4	0.10	14.0	2.05	246.0

GUIDELINES AND CONTROL SETTINGS				
Case Size	Case Application	24hr Energy Usage (kWh)	Discharge Air (°F)	Discharge Air Velocity (FPM)
3' x 3'	Deli	284	21	120
4' x 4'	Fresh Meat	14.61	7	120
4' x 8'	Fresh Meat	28.54	7	120

CONDENSING UNIT DATA						
Case Size	Volts	Phase	RLA (amps)	LRA (amps)	Refrigerant	Refrigerant Charge (lbs)
3' x 3'	120	1	4	23	R290	0.33
4' x 4'	120	1	10	44	R290	0.24
4' x 8'	120	1	20	88	R290	0.24

DEFROST CONTROLS					
Case Application	Case Size	Defrosts per Day	Run Off Time (Min)	Timed Off Defrost (Min)	Timed Off Defrost Termination Temp (°F)
Deli	3' x 3'	3	0	51	47
Fresh Meat	4' x 4'	4	0	23	68
Fresh Meat	4' x 8'	4	0	23	68

NOTES:

- "---" indicates that the feature is not an option on this case model and/or the data is not yet available.
- Notes added are specific to case as pertains to data.
- " * " Indicates the MIDA 8 is supplied with 2 electrical plugs and may be connected to separate circuits with a 15A breaker, or a common circuit with a 25A breaker.

Case Model	Set Point (°F)	Hysteresis (°F)	Application
3x3	26	9.5	Deli
4x4	6	2	Meat
4x8	6	2	Meat



ENGINEERED FOR STORES WITH AMBIENT CONDITIONS NOT TO EXCEED 75° AND 55% RELATIVE HUMIDITY. DUE TO ENGINEERING IMPROVEMENTS SPECIFICATIONS MAY CHANGE WITHOUT NOTICE. ALL MEASUREMENTS ARE TAKEN PER ASHRAE-72-2005 SPECIFICATIONS. HILLPHOENIX REFRIGERATED DISPLAY CASES FOR SALE IN THE UNITED STATES MEET OR EXCEED DEPARTMENT OF ENERGY 2017 REQUIREMENTS. NUMBERS ARE BASED ON STANDARD CASE SIZES. CONSULT ENGINEERING.

MIDA

Rev. Date	Rev. #	Rev. Title
3-9-20	0	NEW RELEASE



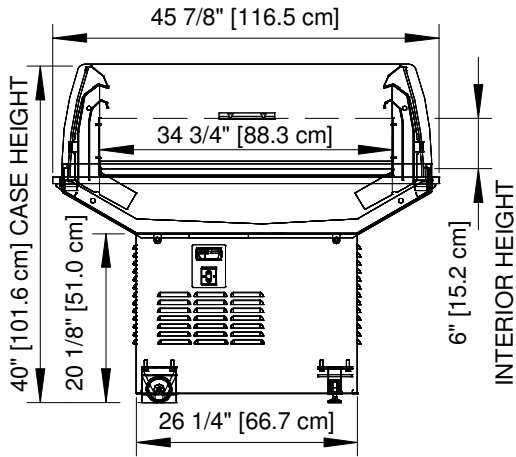

(4'x4') & (4'x8') SECTION

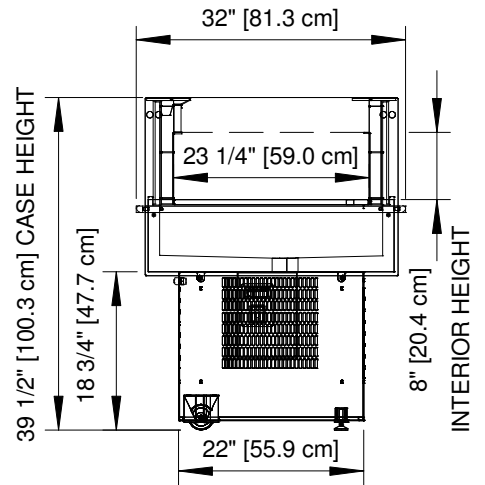

(3'x3') SECTION

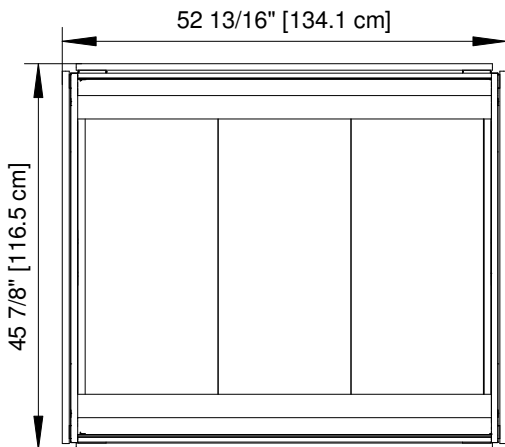

(4'x4') TOP VIEW

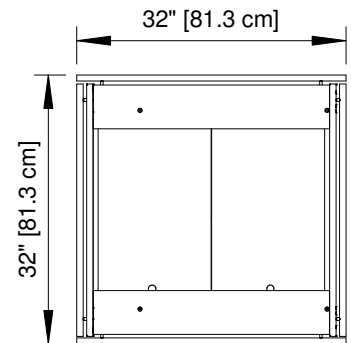

(3'x3') TOP VIEW

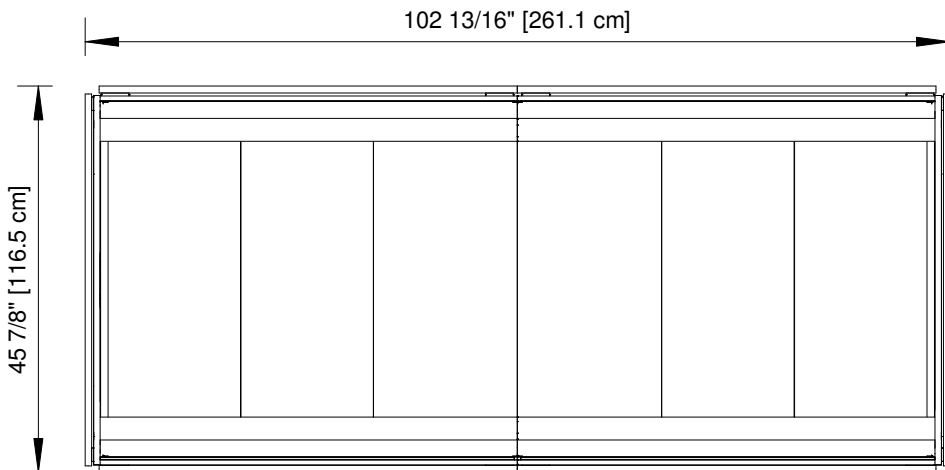

(4'x8') TOP VIEW

GENERAL INFORMATION

Thank you for choosing Hillphoenix for your food merchandising needs. This handbook contains important technical information and will assist you with the installation and operation of your new Hillphoenix display case. By closely following the instructions, you can expect peak performance; attractive fit and finish; and long case life.

We are always interested in your suggestions for improvements (e.g. case design, technical documents, etc.). Please feel free to contact our Marketing Services group at the number listed below. Thank you for choosing Hillphoenix, and we wish you the very best in outstanding food merchandising.

CASE DESCRIPTION

This manual specifically covers the MIDA-4' & 8' meat, deli, dairy, cheese, produce, bakery and meal kits applications and the MIDA-3' for deli, dairy, cheese, produce and bakery applications. This is a self-service open single-deck merchandise refrigerated display case with R-290 refrigerant.

STORE CONDITIONS

Hillphoenix cases are designed to operate in an air-conditioned store that maintains a 75° F (24° C) store temperature and 55% (max) relative humidity (ASHRAE conditions). Case operation will be adversely affected by exposure to excessively high ambient temperatures and/or humidity.

REFRIGERATION SYSTEM OPERATION

Air-cooled condensing units require adequate ventilation for efficient performance.

THIS UNIT CONTAINS R-290 FLAMMABLE REFRIGERANT. USE CAUTION WHEN HANDLING, MOVING OR SERVICING THE DISPLAY CASE. AVOID DAMAGING THE REFRIGERANT TUBING WHICH COULD INCREASE THE RISK OF A LEAK.

SHIPPING CASES

Transportation companies assume all liability from the time a shipment is received by them until the time it is delivered to the consumer. Our liability ceases at the time of shipment.

RECEIVING CASES

Examine fixtures carefully and in the event of shipping damage and/or shortages, please contact the Service Parts Department at the number listed below.

CASE DAMAGE

Claims for obvious damage must be 1) noted on either the

freight bill or the express receipt and 2) signed by the carrier's agent; otherwise, the carrier may refuse the claim. If damage becomes apparent after the equipment is unpacked, retain all packing materials and submit a written request to the carrier for inspection within 14 days of receipt of the equipment.

Failure to follow this procedure will result in refusal by the carrier to honor any claims with a consequent loss to the consumer.

If a UPS shipment has been damaged, retain the damaged material, the carton and notify us at once. We will file a claim.

LOST/MISSING ITEMS

Equipment has been carefully inspected to insure the highest level of quality. Any claim for lost/missing items must be made to Hillphoenix within 48 hours of receipt of the equipment. When making a claim please use the number listed below.

SERVICE & TECHNICAL SUPPORT

For service or technical questions regarding this case, please contact our Service Department at 1-800-283-1109. For questions regarding our refrigeration systems or electrical distribution centers, please contact our Systems Division Customer Service Department at 1-770-388-0706.

CONTACTING THE FACTORY

If you need to contact Hillphoenix regarding a specific fixture, be certain that you have both the case model number and serial number (this information can be found on the data tag, located on the top-left interior of the case). When you have this information, refer to pages 20 and 24 of this manual or

ID PLATE

The display case has an ID plate as illustrated below:

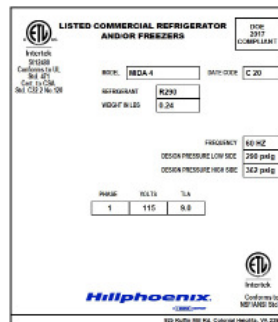

Hillphoenix
1925 Ruffin Mill Rd
Colonial Heights, VA 23834
Mon.-Fri. (8 a.m. to 5 p.m.)
Tel: 1-833-280-5714/Fax: 804-526-7450
Website: www.hillphoenix.com

LOCATION

This refrigerated display case has been designed for displaying and storing perishable food product. It is engineered for air-conditioned stores with a maximum ambient of 75 °F and 55% relative humidity.

When selecting the location for placement of this case, avoid the following conditions:

Excessive Air Movement

1. Doors
2. Air-conditioned vents
3. Other air sources

Excessive Heat

4. Windows
5. Sun
6. Flood lamps 8 feet or less from the product
7. Other heat sources

TRANSPORT AND HANDLING

The display case is shipped wrapped in plastic sheeting and secured to a pallet or in a wooden crate (OPTIONAL). To avoid damage during the various stages of shipping and handling it is good practice to keep the display case fully packaged until it is positioned for final installation.

Handling should be carried out with the aid of a fork-lift truck or appropriate equipment that can lift the display case at the load point indicated by the relevant label on the packaging (see fig. 1).

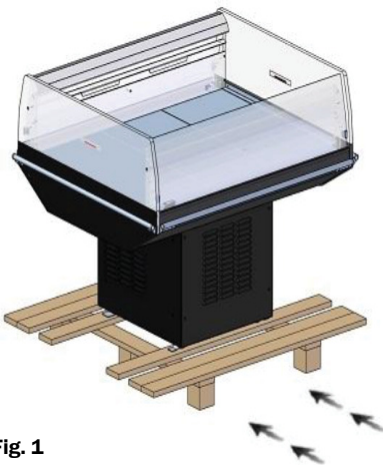

Fig. 1



NOTE

Remove the plastic packaging and all plastic wrap off the panels of the case including the deck pans. Pay careful attention to the accessories packaged together in the shipped loose parts inside the display case bearing in mind that electrical equipment and drainage points are located on the bottom of the display case.

STORE CONDITIONS

The temperature where the display case is stored must not exceed 131 °F. The display case must be shielded from sunlight and weather. Leave the display case inside its original packaging, which will provide it with excellent protection up to the moment of installation.

POSITIONING AND INSTALLATION

Removing the plastic packaging

Removing the shipping pallet

Remove the display case from the shipping pallet as follows:

1. Remove the panels to gain access to the fixing brackets (Fig. 2).
2. Undo all the screws (a) that fix the bracket (b) to the pallet and the legs of the display case itself.
3. Lift the display case and remove the pallet (c).



WARNING

Be certain that your hands and feet are out of the way before lowering the case. Failure to do so may result in serious injury.

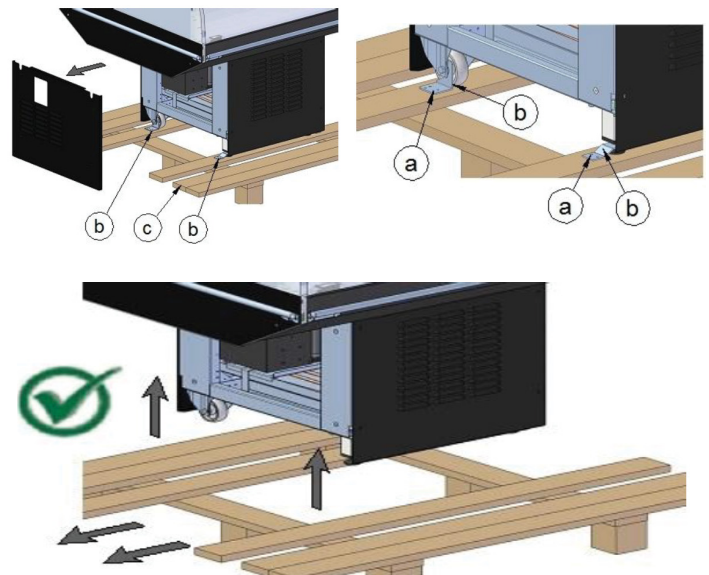

Fig. 2



DANGER

Electrical equipment and water drainage points are located underneath the display case. **Do not use front panels and uprights as lift points!**

CASE INSTALLATION

Positioning the cabinet

Respect the conditions shown in the figures below and the indications in "TECHNICAL DATA".

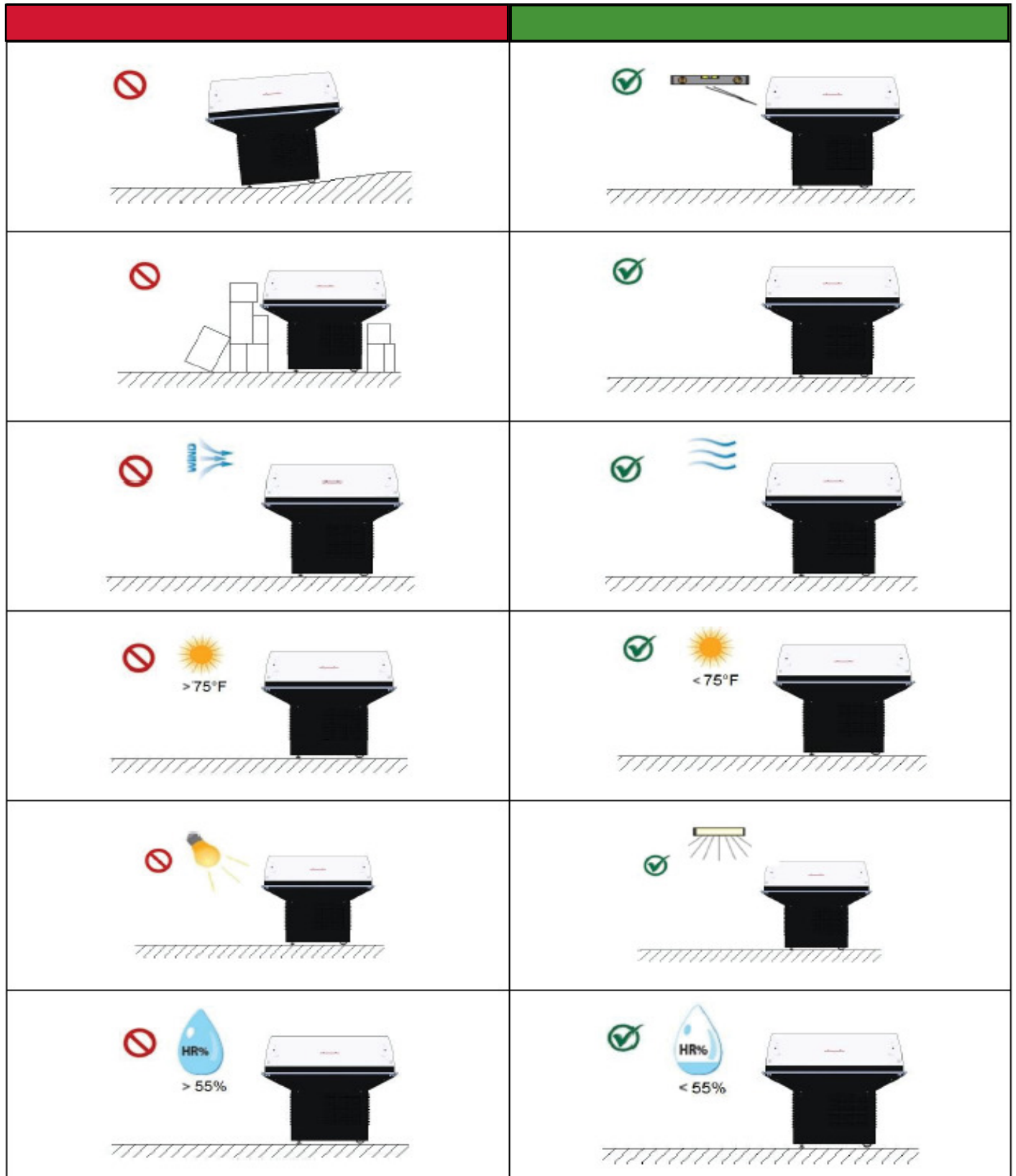

Fig. 3

⚠ DANGER

These cases are not designed for excessive external weight. Do not walk on top or inside of cases. Doing so may result in case damage and/or personal injury.

Horizontal positioning and adjustment

Position the display case horizontally using a spirit level, placing it, for example, in the lower areas illustrated in Fig. 4. Adjust using the adjustable feet supplied with the cabinet.

The height of the cabinet above the ground can be adjusted as shown in Fig. 4 below.



Fig. 4

👉 NOTE

Failure to properly level the case could result in lack of proper condensation drainage leading to failure of the unit.

COMPRESSOR COMPARTMENT DIAGRAM

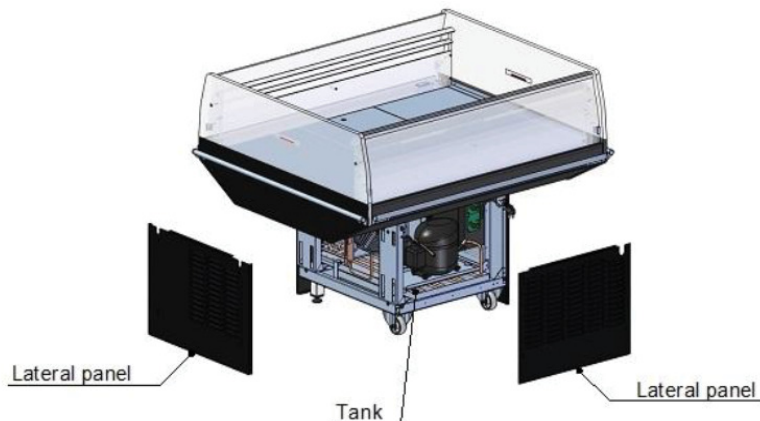

Fig. 5

👉 NOTE

Do not obstruct ventilation around the base of the display case condensing unit. Obstructing could cause the case to not operate correctly and failure to maintain product temperatures.

👉 NOTE

Remove all plastic wrap from all items in the case including the deck pans before operating.

Bumper Installation:

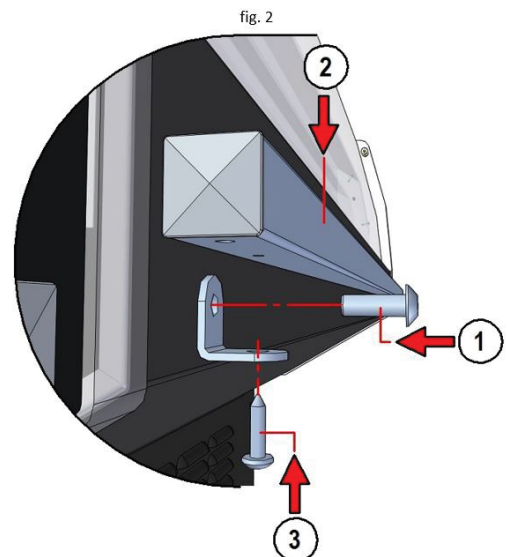
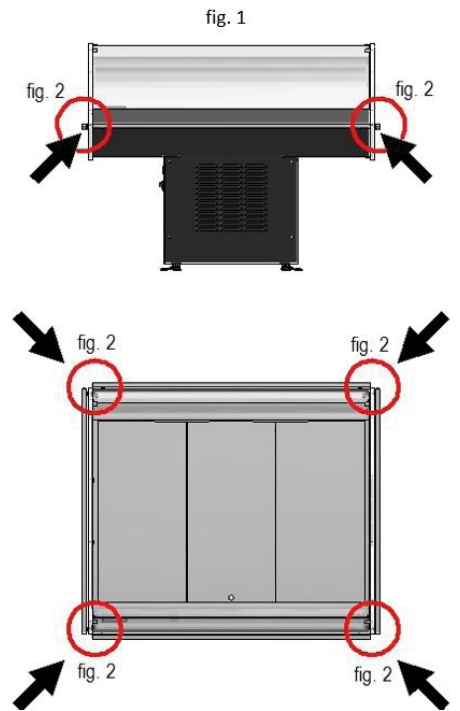

CASE CONNECTION

ELECTRICAL

Electrical hookups are made through the electrical raceway that can be accessed by removing the front lower panels of the display case.

When connecting to the power supply on the case, field wiring should exit box from the side furthest away from case wiring to allow more room inside for wiring connections. The case must be grounded. For more detailed electrical wiring information (see Appendix A1).

Prior to plugging in and starting up the case always check the data tag located on the left end exterior lower panel. This case utilizes a NEMA 5-15 plug that comes wired to the display case (Fig. 6) which can be found at the rear base panel. **Note: Check that the voltage of the receptacle you are going to use for power and the voltage required for the case match.**



Fig. 6 Main power cord plug type

DANGER

Prior to plugging in and starting up the case. Be certain that the voltage of the receptacle you are going to use and the voltage required for the case match. Failure to do so may result in case/system damage.

DANGER

Be certain that all electrical connections are compliant with local codes.

DANGER

CAUTION, RISK OF ELECTRIC SHOCK. If the cord or plug becomes damaged, replace only with a cord and plug of the same type.

The display case must be connected to a main power source that complies with electrical safety standards and is equipped with a high-sensitivity magneto-thermal cut-out.

Before plugging the display case in to the main power check the following:

- The power to the display case will be connected to has a ground connection in compliance with current safety standards and the display case is properly grounded.
- The voltage corresponds to the data tag as indicated on the various electrical components and power supply.
- There are no excessive power voltage drops (as verified at the case power supply terminals) or wires of unsuitable cross-section or in any case non-compliant with standards in force: these could cause malfunctions and/or create serious damage to the case electrical components and also render the warranty null and void.
- The refrigerated display case power supply is independent of other power supplies and can be disconnected separately;
- Before inserting the plug in the main power source, check that the switch is *OFF*. Insert the plug and then switch *ON*. The value of the line protection fuse or magneto-thermal cut-out must correspond to that indicated in the test report.

REFRIGERATION & COMPRESSOR COMPARTMENT

The bottom mounted compressor compartment can be accessed by removing the front, rear or side panels.

Power Supply

1. Ensure the case power switch is in the off position.
2. Plug the main power cord (Fig. 6) located at the rear base panel of the case into the power source.
3. Turn the power switch to the ON position (Fig. 7). The case should begin normal operations.



Fig. 7 Lower panel switch locations

COMPRESSOR COMPARTMENT DIAGRAM

- A** Condenser Fan
- B** Compressor
- C** Fan Control Board: On-cycle
- D** Fan Control Board: off-cycle
- E** Electrical Junction Box
- F** Drain
- G** Dissipater Pan
- H** Suction Line
- I** Discharge Line

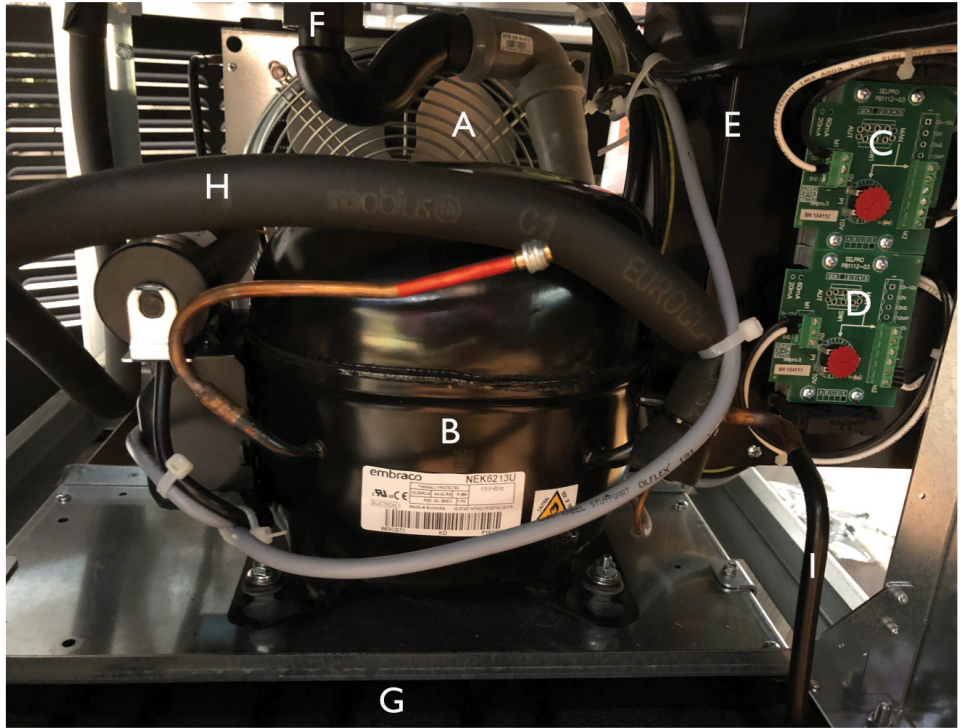

Fig. 8

Note: Access locations and/or compartment configurations will vary based on case design.

CONTROLS ON THE CONDENSING UNIT

The control panel is in the lower section of the cabinet. See Appendix for full instructions on how to program the Carel electronic controller.



Picture	Function	Operates on	Adjusts
	Switch on/off	Power supply to control panel. Thermostat	//
	Switch on/off	Condensing unit motor	//
	Adjustment	//	Case temperature Defrost cycle

Fig. 9

NOTE
See Appendix for full instructions on how to program the Carel electronic controller.

⚠ DANGER
ALWAYS CHECK THE THERMOSTAT CURRENT RATING because it may have a limited current, as low as 2A. If necessary protect digital thermostat contacts with a contactor.

⚠ DANGER
When carrying out maintenance tasks inside the refrigerated case or compressor compartment, it is essential to disconnect the power source to the case from the main power.

The set point and hysteresis values

Case Model	Set Point (°F)	Hysteresis (°F)	Application
3x3	26	9.5	Deli
4x4	6	2	Meat
4x8	6	2	Meat

CASE CONNECTION

SAFETY LABELS

Inspect the refrigerated display case and ensure all safety warnings/information applied on the refrigerated case are not removed. Any labels removed must be replaced. The following signs are applied:







Warning #.	Description of Warning	Symbol/Information	Application
1.	ID Plate		Close to Field Wiring Box
2.	Danger: connect to an electrical system with a magneto-thermal cut-out		On Field Wiring Box
3.	Danger: connect to an electrical system with a magneto-thermal cut-out		On electrical panel. Power lead
4.	Danger: Do not lift. Disconnect electrical power first; do not use water jets directly; moving parts; disconnect electrical power.		On all fan holders
5.	Ground connection point.		On the electrical switch box.
6.	Type label	ANSI/NSF-7 Type 1 Display Refrigerator intended for 75 °F/55%RH	Close to Field Wiring Box
7.	Intended use label	This equipment is intended for the storage of packaged products only	Close to Field Wiring Box
8.	Load limit		On side glass/fixed and/or mobile
9.	Danger: Risk of fire or explosion. Flammable refrigerant used. Do not use mechanical devices to defrost refrigerator. Do not puncture refrigerant tubing.		Flammable locations

Fig. 10

Before powering-up the case, be certain that all of the steps listed below have been completed to ensure proper case functionality, safety and compliance with warranty terms.

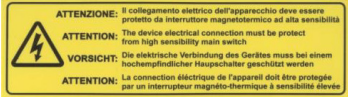
- Have you thoroughly examined the case for shipping damage? (see pg. 4)**
- Have you checked to ensure the case is horizontally level? (see pg. 5-7)**
- Have you checked all exposed refrigeration lines to ensure that they are not kinked, dented or rubbing together and have installed the compressor compartment access panel? (see pg. 8)**
- Have you checked and verified the voltage of the receptacle you are going to use for power and the voltage required for the case match? (see pg. 8)**
- Have you verified the display case switch is in the OFF position prior to plugging in to the main power source? (see pg. 8)**
- Have you reviewed safety warning labels and verified all are present and in good condition? (see pg. 10)**

After powering-up the case, be certain that all of the steps listed below have been completed to ensure proper case functionality, safety and compliance with warranty terms.

- Check case temperature and adjust controller as needed. All display case connections comply with the information/instructions? (see pg. 9)**
- Store the installation manual in the vicinity of the display case itself to where it can be accessed and consulted by all members of staff involved in the use of the refrigerator display case.**
- Before placing food in the display case, allow the case to operate for approximately two (2) hours and ensure the case is at the proper temp before loading.**

AIRFLOW & PRODUCT LOAD

Hillphoenix cases provide maximum product capacity within the refrigerated air envelope. Please keep products within the appropriate load limit.

It is important that you do not overload the food product display so that it impinges on the airflow pattern (Fig. 11). Overloading will cause malfunction and the loss of proper temperature levels.

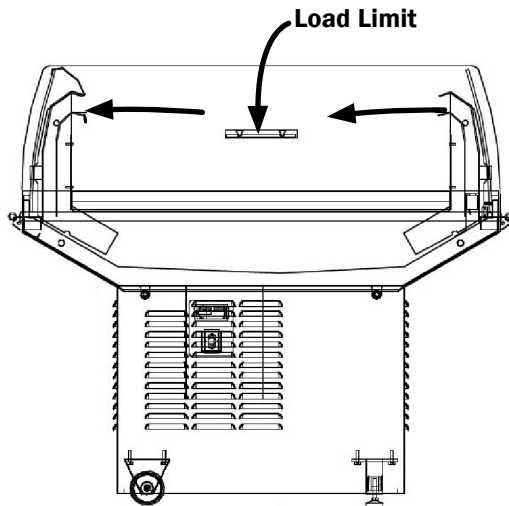

Fig. 11

The refrigerated case is marked with a line to indicate the load limit (see Fig. 12).

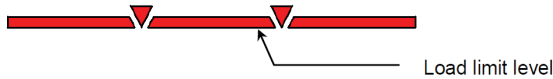

Fig. 12

Adequate refrigeration is only guaranteed for products that is displayed below this line. Arranging the goods in a uniform manner ensures the best possible working efficiency of the display case.

It is good practice to carry out rotation of stock when refilling the cabinet with new products. Older products must be sold first. Products must not obstruct air vents.



NOTE

Proceed to the loading only once the display case has reached the proper temperature setting.



FORBIDDEN

DO NOT OVERLOAD THE CASE: this is the most common error and can cause secondary faults and malfunctions (e.g. blocking the evaporator by obstructing cold air outflow). Note also that products lying above the load limit line will not be properly refrigerated and this will inevitably cause their rapid deterioration.



FORBIDDEN

1. Do not load products above the load limit line.
2. Do not tamper with safety devices. Any tampering shall render the warranty null and void and shall exonerate Hillphoenix from any liability with regard to users of the refrigerated display case.
3. Do not stand on any part of the refrigerated display case.
4. Do not enter any condensing unit compartment of the refrigerated case unless an authorized service technician.
5. Do not use water jets directly to clean the cabinet.
6. Do not remove the electrical panel front cover.
7. Do not attempt to remove build-ups of ice with sharp objects.
8. Do not clean with acid products or products with a strong degreaser or corrosive action; do not use abrasive sponges.

Defrosting

The defrost cycle is very important in that it ensures correct operation of the cabinet. It is activated and controlled by the thermostat which temporarily stops the condensing unit, allowing the evaporator to shed the build-up of ice. Fan speeds during defrost and refrigeration are independently adjustable using the Rheostat boards shown in Figure 7 on Page 9 (Items C & D). The default settings utilize a higher fan speed during defrost to minimize off time and ensure a clear coil. For factory settings see page 2 of this manual 'TECHNICAL DATA'.



DANGER

Flammable

DANGER – Risk Of Fire or Explosion. Flammable Refrigerant Used. Do Not Use Mechanical Devices To Defrost Refrigerator. Do Not Puncture Refrigerant Tubing.



CASE CLEANING

A periodic cleaning schedule should be established to maintain proper sanitation, insure maximum operating efficiency, and avoid the corrosive action of food fluids on metal parts that are left on for long periods of time. Further suggestions for case cleaning include the following:

- Remove all food from the refrigerated display case prior to cleaning.
- To avoid shock hazard, be sure all electrical power is turned off before cleaning. In some installations, more than one disconnect switch may have to be turned off to completely de-energize the case.
- Remove the interior deck pans and any removable internal panels as shown in Fig. 13 for cleaning.
- The bottom of the inside tank and the area underneath the evaporator should also be cleaned with the same frequency where the display case is exposed to fluid spillage or liquid drainage from merchandised products.
- All surfaces pitch downward to a deep-drawn drain trough, funneling liquids to the center of the case where the waste outlet is located for easy access. Check the waste outlet to insure it is not clogged before starting the cleaning process and avoid introducing water faster than the case drain can carry it away. It is recommended that this case be wiped down rather than hosed to avoid overflowing the condensate pan.
- Clean from top to bottom when cleaning the display case to avoid cross contamination.
- Avoid spraying any cleaning liquids directly on the electrical connections.
- Allow cases to be turned off long enough to clean any frost or ice from coil and pans.



Fig. 13 Removable parts for cleaning.



NOTE

All washed parts must be rinsed and air dried prior to the case being reconnected to the power source.

Fans and Fan Plenum

1. Disconnect power to the case and wait for fans to come to a complete stand-still.
2. To access the underside of the fans, the coil or the tank (Fig. 14). Lift the fan plenum and clean as necessary. Use a spray bottle filled with an approved mild detergent and warm water.
3. Be sure to move the fan plenum back to its original position after cleaning and/or inspection is complete.

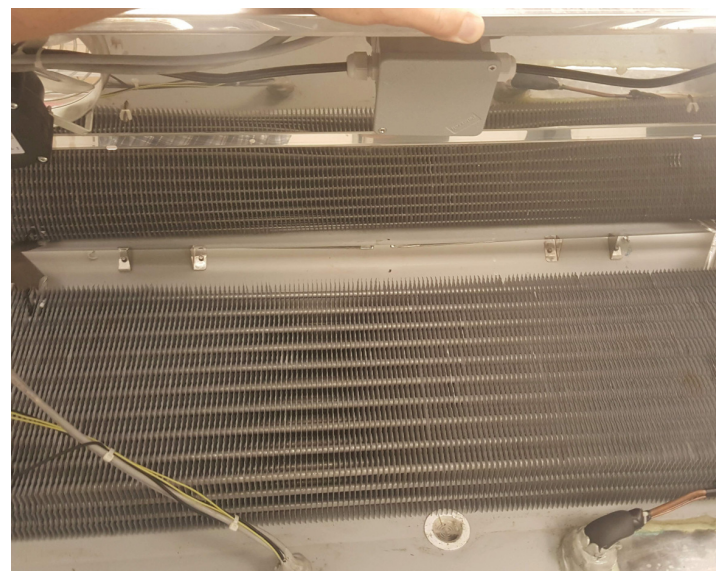

Fig. 14 Fan and Fan Plenum



DANGER

SHOCK HAZARD

Always disconnect power to case when servicing or cleaning. Failure to do so may result in serious injury or death.



NOTE

Use specific products for disinfection and cleaning; use soft, non-abrasive sponges or rags!



FORBIDDEN

Do not use alcohol, solvents or derivatives for cleaning surfaces on plexiglass. It's use makes it fragile at the treated surface and causes the formation of cracks and thus inevitably the break.

⚠ DANGER

When carrying out cleaning work or maintenance on the condensate collection tank it is essential to disconnect the machine and all its accessories from the mains power!

WARNING!!! DANGER OF BURNS

Be careful of the elements inside the condensate evaporation tank: they operate at high temperature!!

👉 NOTE

Maintenance workers are advised to use gloves to protect themselves against cuts and abrasion in that, while all the corners of the sheet metal have been folded back, there may still be some sharp edges. Do not wear accessories (necklaces, bracelets etc.) or loose, flapping or hanging clothing as it could get caught up in the structure.

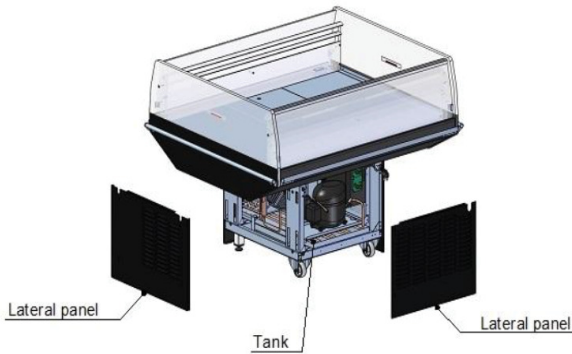

Fig. 15 Removing condensating unit panels

CHECKING AND CLEANING THE CONDENSATE COLLECTION TANK

Inspect the condensate collection tank at least once every 6 months. Remove the lateral panels and clean the tank (see Fig. 15). Ensure you disconnect the electrical power supply and make sure you DO NOT touch the elements as they reach high temperatures (necessary for evaporation inside the tank).

Cleaning the condenser of the condensing unit

The condensers used on the condensing units gather dust and dirt and must be cleaned regularly. Under normal working conditions this task must be executed at least once a month using a soft-bristled brush and a vacuum cleaner. A dirty condenser will reduce the display case performance: it will also result in increased energy consumption. (See Fig. 17)

⚠ CAUTION

Be sure to clean the condenser air intake filter monthly. Failure to do so may result in loss of normal compressor functions and case damage.

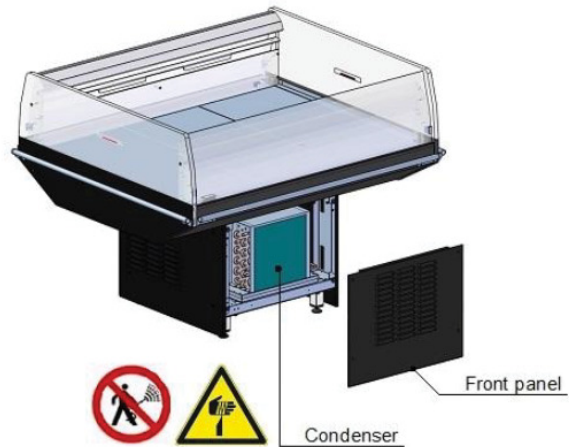

Fig. 16 Cleaning the condensing unit

UNSCHEDULED CASE MAINTENANCE

Unscheduled maintenance concerns all those tasks that cannot normally be carried out by the routine user as specified on pages 13-14. Such tasks require qualified personnel with specific technical skills (e.g. refrigeration system specialists, electricians etc.) and must be carried out at least once a year. See the scheduled maintenance table for a list of the main tasks. (Fig. 16).

If inspection reveals any rust, cracks and etc...it will be necessary to carry out repairs and/or replacement of parts so that the case meets code and the display case is in prime operating condition. To enhance safety, it is recommended that you always seek the advice of a specialized technician before carrying out any repair work.

PARTS SUBJECT TO WEAR AND SPARE PARTS

Most spare parts carry clear, complete ID information. It is important that the refrigerated case parts be replaced by analogous parts of equivalent safety and quality: to order spare parts please contact Hillphoenix, stating the case model and serial number, found in this manual or on the case ID plate, and provide a description of the component and the desired quantity. Refer to the Parts section in the back of the manual for parts ordering and to identify parts that may need to be replaced.

⚠ CAUTION

Do not pressure wash equipment as damage to electrical components may result.

SCHEDULED MAINTENANCE TABLE

Maintenance	Weekly	Monthly	Half Yearly	Yearly
Cleaning case	✓			
Cleaning gas condenser		✓		
Case visual check	✓			
Safety labels visual check	✓			
Check electric system				✓
Check water drainage system.			✓	
Check refrigeration system				✓
General inspection				✓

Fig. 17 Recommended cleaning schedule

TROUBLESHOOTING

INSTRUCTIONS FOR PERSONNEL

In the event of General Emergency

Immediately inform those in the vicinity of the perceived danger, gesticulating if necessary; cut the electrical power to the cabinet.

In the event of Fire

In the event that the refrigerated case catches fire or is involved in a fire it is possible to use an extinguisher with a powder-type or CO2 extinguishing agent.

Resetting the Case

To restore normal operation it is necessary to eliminate all the causes of the emergency situation; if necessary repair or replace damaged parts.



NOTE

If safety devices are tripped it will be necessary to identify the cause before continuing work.



CAUTION

Do not store or use gasoline or other flammable vapors and liquids in the vicinity of this or any other appliance.



CAUTION

R-290 flammable refrigerant in use. Improper installation, adjustment, alteration, service or maintenance can cause property damage, injury or death. Read the installation operating and maintenance instructions thoroughly before installing or servicing this equipment.



DANGER

Flammable

DANGER – Risk Of Fire or Explosion. Flammable Refrigerant Used. Do Not Use Mechanical Devices To Defrost Refrigerator. Do Not Puncture Refrigerant Tubing.



FAILURES AND SHOOTING

Failures

In the event of a failure of mechanical/electrical/refrigeration parts the initial safety conditions must be restored immediately by replacing or repairing such faulty parts.

Table of failures and shooting

PROBLEM	POSSIBLE CAUSE	SOLUTION
The refrigerated cabinet does not work.	<ol style="list-style-type: none"> 1) the mains circuit breaker is set to OFF; 2) the power line between refrigerated cabinet and power socket is faulty; 3) the switch on the refrigerated cabinet control panel is not switched on. 	<ol style="list-style-type: none"> 1) turn the mains power on; 2) make sure the plug is inserted properly in the socket; 3) turn the power switch on the refrigerated cabinet panel to ON.
The refrigerated cabinet does not cool enough.	<ol style="list-style-type: none"> 1) the temperature thermostat is adjusted incorrectly; 2) the refrigerated cabinet has been filled too much 3) the condensing unit is clogged with dust 4) the evaporator is covered in ice 	<ol style="list-style-type: none"> 1) reprogram the temperature thermostat; 2) remove goods and observe the maximum load level; 3) clean the condensing unit with a soft-bristled brush and vacuum cleaner 4) carry out a defrost cycle.
The refrigerated cabinet cools too much.	<ol style="list-style-type: none"> 1) the temperature thermostat is adjusted incorrectly. 	<ol style="list-style-type: none"> 1) reprogram the temperature thermostat;
The refrigerated cabinet runs continuously.	<ol style="list-style-type: none"> 1) the temperature thermostat is adjusted incorrectly; 2) the refrigerated cabinet has been filled too much and is preventing correct air circulation. 	<ol style="list-style-type: none"> 1) reprogram the temperature thermostat; 2) remove goods and observe the maximum load level.

SAFETY DEVICES

FORBIDDEN

It is absolutely forbidden for the user to tamper with safety devices. Before using the refrigerated case check that mechanical safety covers are properly in place. Any tampering shall render the warranty null and void and exonerate Hillphoenix from any liability with regard to users of the refrigerated case.

Only maintenance personnel may carry out maintenance tasks involving safety devices. These tasks are listed below.

SAFETY DEVICE	SCOPE OF INTERVENTION	ACTION
Incorporated over-pressure cut-out	On incorporated condenser unit compressor	Cuts the electrical power of the compressor if the pressure of the refrigerant rises above the safety limits.
Fixed cover on electrical control panel. Remove only with aid of tools	Electrical control panel	Prevents access to live parts. Electrical danger warning sign applied (see "DESCRIPTION OF DANGERS AND RISKS RESIDUAL")
Fixed safety gratings. Remove only with aid of tools	On evaporator fans.	Prevents access to fans when they are running or slowing down to a stop.

DESCRIPTION OF DANGERS AND RISKS RESIDUAL

Residual Dangers

Dangers that have not been reduced/eliminated with the safety measures adopted on the refrigerated case can nevertheless be reduced/eliminated as long as users apply proper managerial practices. Users must:

- Ensure that all safety warning and labels are always in good condition; inspect them periodically and have them replaced whenever necessary.
- Do not install any spare parts that are not identical to the originals or of equivalent performance.
- Do not carry out any modifications or structural work without approval from Hillphoenix or a qualified field service technician.
- Should the refrigerated case be dented, inspect the structure visually or have qualified personnel carry out an inspection.

After a long period of disuse have a qualified field service technician carry out an inspection of the case to check that it is in good condition and working properly.

Residual Risks

While the refrigerated case has been designed to ensure maximum safety, there nevertheless remain some residual risks. Hillphoenix has identified the main **dangers and residual risks for users and maintenance personnel** as follows in chart below:

DESCRIPTION OF RESIDUAL RISK	CAUSE	SAFETY MEASURES
Danger of falls in area surrounding the cabinet	Presence of: stairs, columns etc. and/or slippery floors and objects and/or work tools	Mark out the relevant zones and highlight them with warning signs and symbols (e.g. yellow/black striped marker tape on stairs etc.) that are visible during both routine use and maintenance.
Danger of objects accidentally falling	Haphazard storage of tools/objects.	Use tool boxes in work areas. Ensure personnel are trained.
Danger of injury to hands, arms, legs and head	During cleaning and maintenance there may be objects or parts of the cabinet protruding from the case itself (e.g. glass covers open during cleaning)	Mark out the work area with appropriate barriers. Always use the recommended personal safety devices.
Risk of refrigerating gas leaks	Accidental damage to pipes	Immediate shutdown of case operation. Disconnect electrical power supply. Contact a service technician.

SAFETY DEVICES & SERVICE

REFRIGERANT

This piece of equipment uses a R-290 Refrigeration system. This equipment has been clearly marked on the serial tag the type of refrigerant that is being used. There is also a warning labels stating that the unit contains R-290 refrigerant.

No smoking or open flames when servicing this equipment. If needed, use a CO2 or dry=power type fire extinguisher

Only authorized service technician, certified in R-290 system should service this equipment.

MANIFOLD SET

A R-134A manifold set can be used for servicing this equipment.

REFRIGERANT RECOVERY

Follow all national and local regulations for R-290 refrigerant recovery.

LEAKING CHECKING AND REPAIR

Leak check an R-290 system the same way you would an R-134a or R-404A system with the following exceptions.

1. Do not use a Halid leak detector on a R-290 system.
2. Electronic leak detector must be designated specifically for combustible gas.

Use of a bubble solution or an ultrasonic leak detector are acceptable.

When repairing a leak, it is recommended using oxygen free dry nitrogen with a trace gas not exceeding 200PSI.

When accessing an R-290 system, piercing valves are not to remain on the equipment in a permanent manner. After charge is recovered, Schrader valves are to be installed on the process stubs. Proper charge is to be weighed into the system and the system is to be leak checked afterwards.

The R-290 equipment must have red process tubes and other devices through which the refrigerant is serviced, such as any service port. This color marking must remain on the equipment. If marking is removed, it must be replace and extend at least 2.5 centimeters (1") from the compressor.

CAUTION

Component parts shall be replaced with like components. Service work shall be done by factory authorized service personnel, so as to minimize the risk of possible ignition due to incorrect parts or improper service.

CHARGING

Follow the charge amount specified on the data tag. It is recommended to use the shortest hoses possible to prevent undercharging.

- Ensure the system is sealed and leak checked
- Evacuate system to a minimum 500 micron
- Weigh in correct charge
- Leak check the system again
- Bleed the refrigerant from the high side hose to the low side hose
- Disconnect the hoses
- Remove line taps

DANGER

Flammable

DANGER – Risk Of Fire or Explosion. Flammable Refrigerant Used. Do Not Use Mechanical Devices To Defrost Refrigerator. Do Not Puncture Refrigerant Tubing.



CAUTION

It is highly recommended that a technician servicing a case with HC refrigerant is aware of safety considerations and maintenance procedures on how to safely handle flammable refrigerants.

Hillphoenix

A **DOVER** COMPANY

Contact the Service Parts Department at:

Shop Online: www.partsonestore.com
Email: orderparts@doverfoodretail.com
Phone: 833-3PARTS1 (1-833-372-7871)
For MIDA parts: choose (Case)

Provide the following information about the part you are ordering:

- **Model number and serial number*** of the case for which the part is intended.
- **Length of the part** (if applicable).
- **Color of part** (if painted) or color of polymer part.
- **Whether part is for left or right-hand application.**
- **Quantity**

***Data tag is located on the base of the display case.**

If the parts are to be returned for credit, contact the Parts Department. Do not send parts without authorization.

PARTS LIST

PARTS INDEX MIDA-4x4 and MIDA-4x8

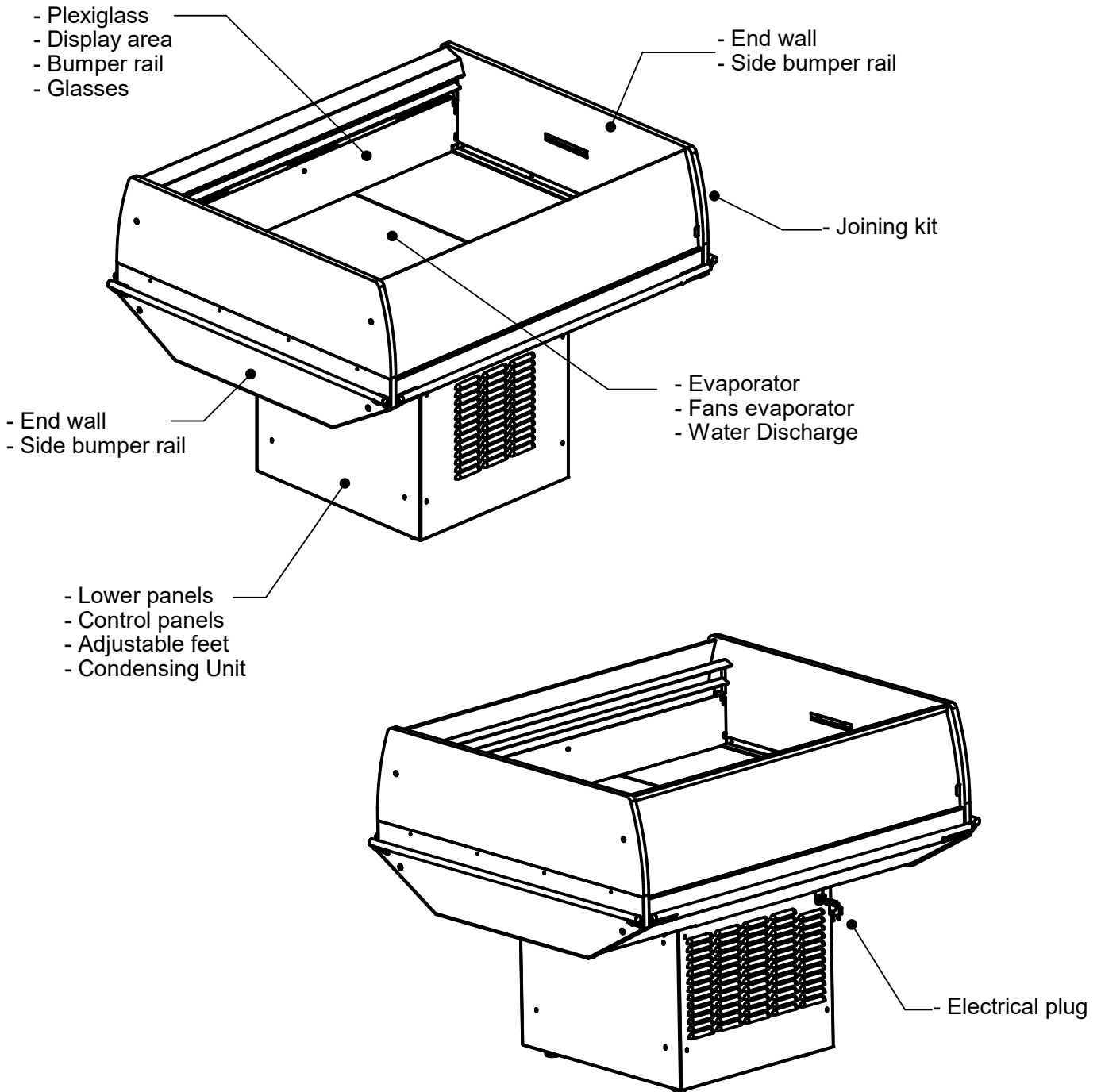

	<input type="text"/>	

Provide the following information about the part you are ordering:

- Model number and serial number* of the case for which the part is intended.
- Length of the part (if applicable).
- Color of part (if painted) or color of polymer part.
- Whether part is for left or right-hand application.
- Quantity

END WALLS / SIDE BUMPER

LEFT END WALL

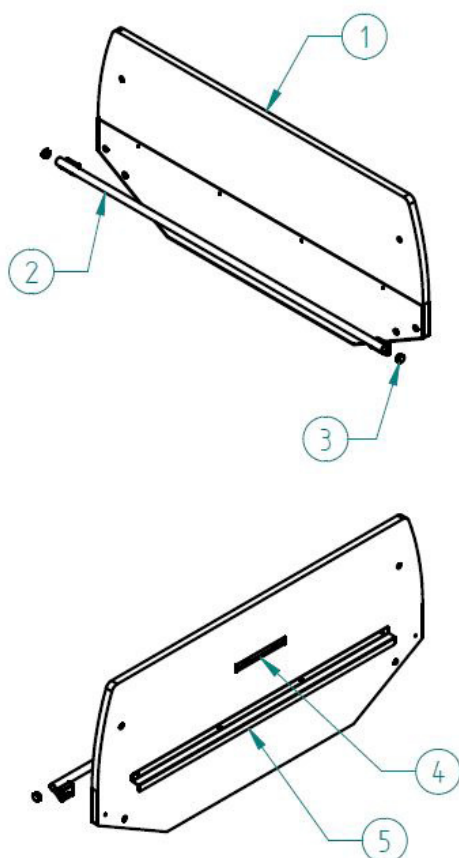

LEFT END WALL

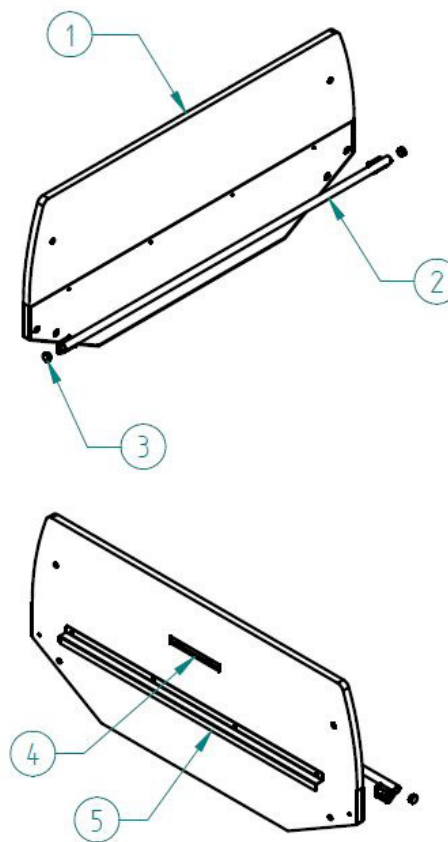

#	DESCRIPTION	LEFT	PCS	RIGHT	PCS
1	Plexiglass end wall	P113544B	1	P113544B	1
2	End wall bumper rail kit Ø20 mm	P113545M	1	P113546H	1
3	Cap for bumper rail Ø20 mm	P113547F	2	P113547F	2
4	Support for Plexiglass end wall	P113548D	1	P113548D	1
5	Label "Load limit line"	P113549B	1	P113549B	1

PARTS LIST

PLEXIGLASS/BUMPER RAIL / DISPLAY AREA

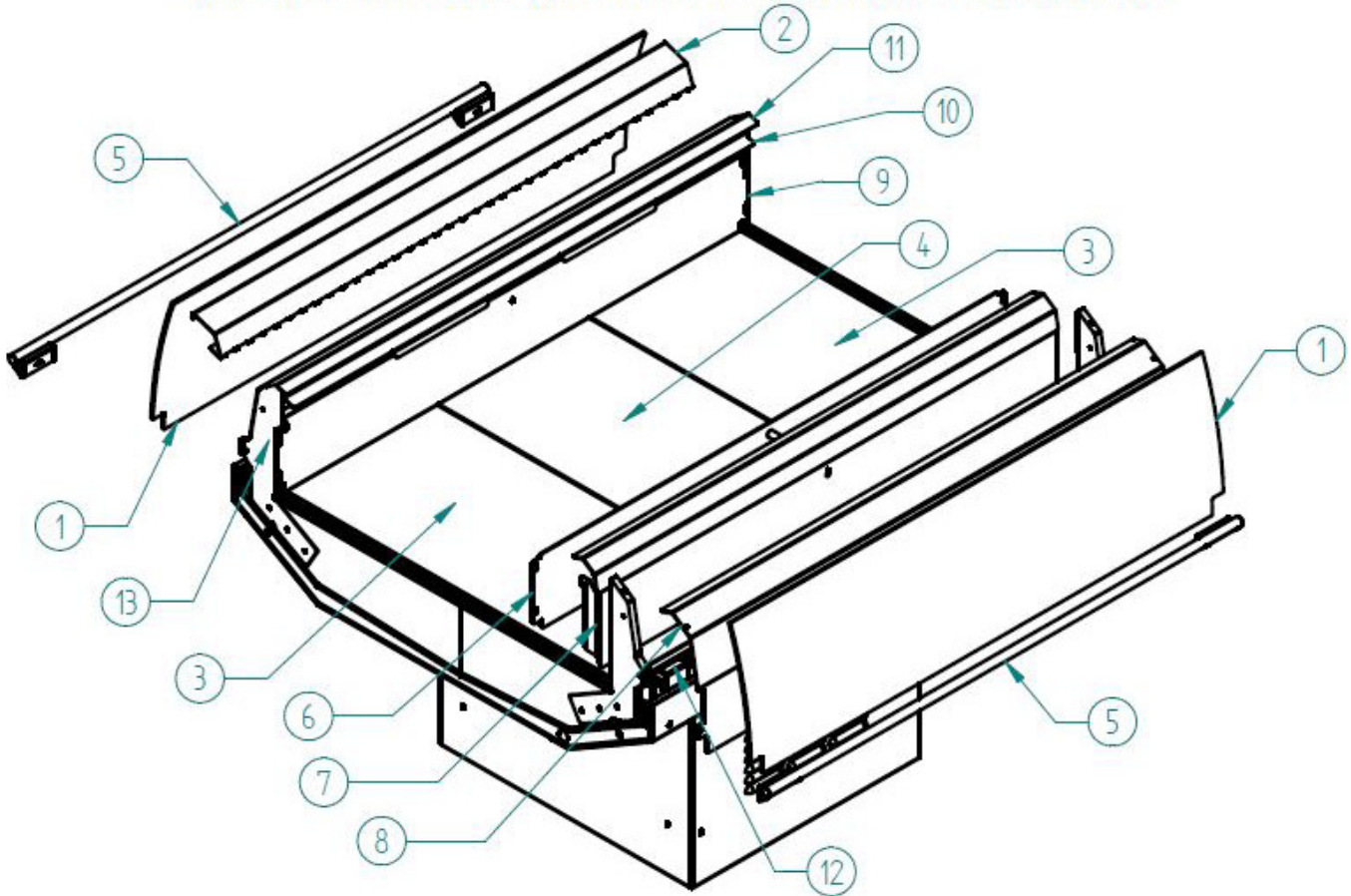

#	DESCRIPTION	Part Number	PCS
1	Tempered Front and Rear curved glass	P113550K	2
2	Anti-condensation Front	P113551G	1
3	Display deck without hole	P113552E	2
4	Display deck with hole	P113553C	1
5	End wall bumper rail kit Ø20 mm	See prior page	2
6	Product holder	P113554A	1
7	Rear Air inlet	P113555K	1
8	Rear closed air inlet	P113556G	1
9	Product holder	P113557E	1
10	Rear Air inlet	P113558C	1
11	Rear closed air inlet	P113559A	1
12	Solar Thermometer	P113560H	1
13	Air inlet end wall dx/sx	P113561F	4

EVAPORATOR / EVAPORATOR FANS

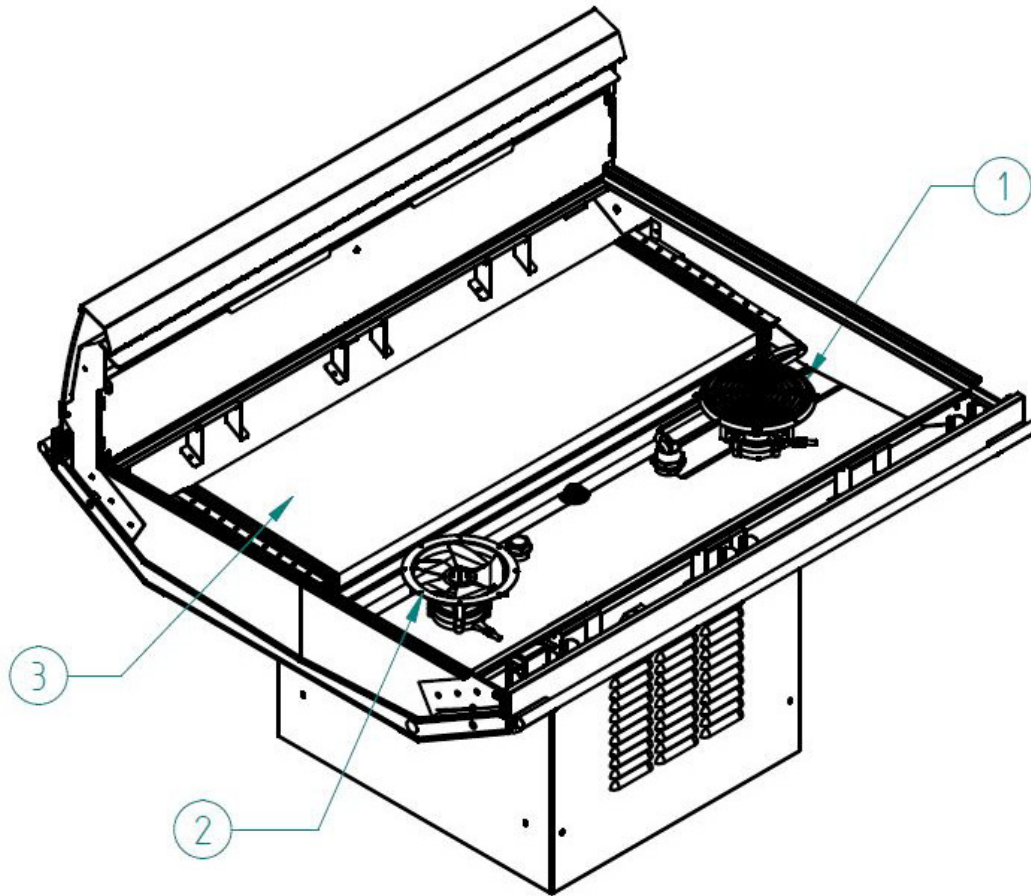

#	DESCRIPTION	Part Number	PCS
1	Protective metal grid Ø200 for evaporator fan	P113562D	2
2	Evaporator fan complete with impeller and metal ring	P113563B	2
3	Evaporator R290	P113564M	1

LOWER PARTS

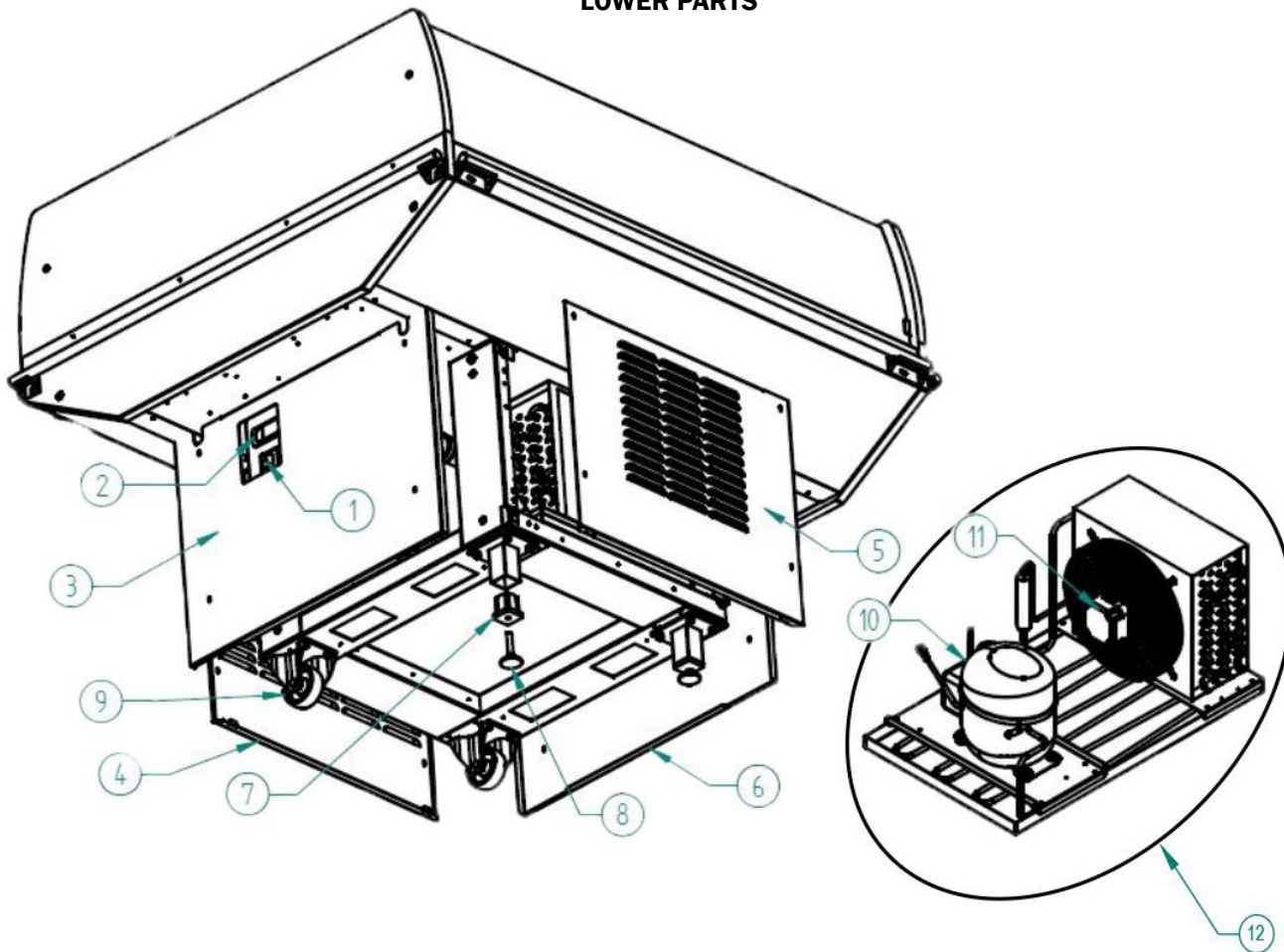

#	DESCRIPTION	Part Number	PCS
1	ON-OFF switch 16A	P113565H	1
2	Carel Thermostat PJEZCOH100 115V 3 RELE 2HP 2NTC	P113566F	1
3	Left side base panel INOX	P113567D	1
4	Rear base panel INOX	P113568B	1
5	Front base panel INOX	P113569M	1
6	Right side base panel INOX	P113570G	1
7	Adjustable feet support 40X40 SP.1,5 M10	P113571E	2
8	Adjustable feet TH40 M10X65	P113572C	2
9	Support Whell Ø80 fixed	P113573A	2
10	Compressor NEK6213U R290	P113574K	1
11	Condensing fan motor	P113575G	1
12	Condensing Unit SP 0905.083A	P115686M	1

ELECTRICAL CORD

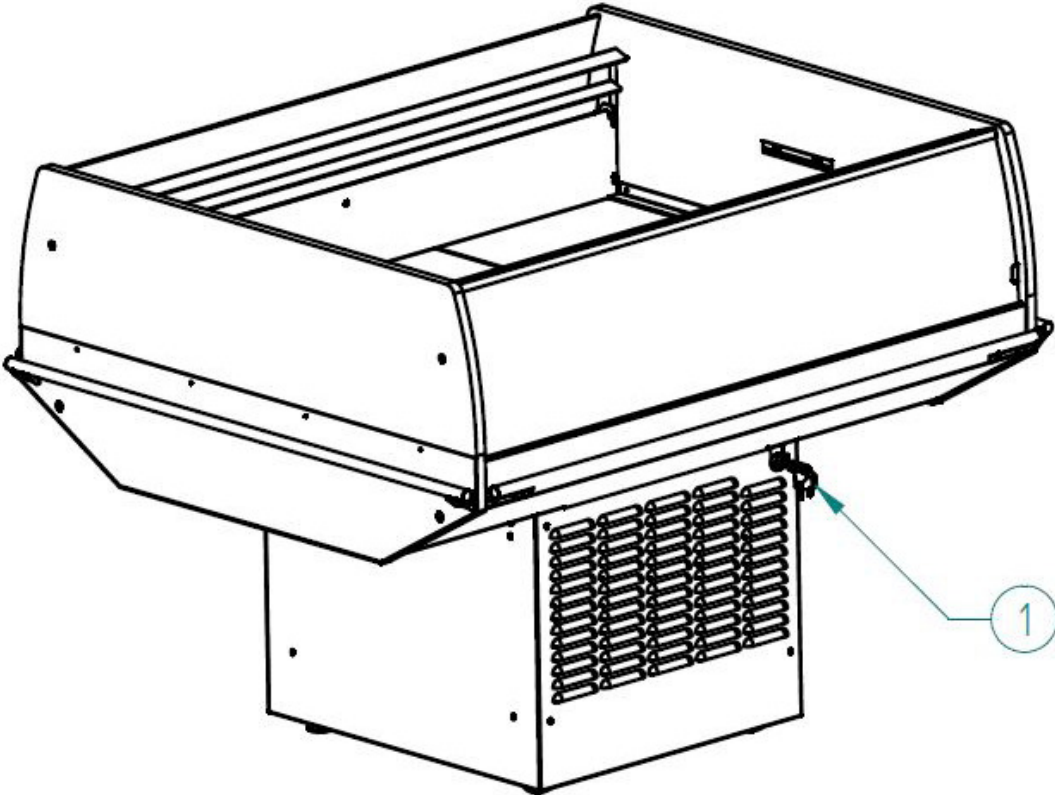

#	DESCRIPTION	Part Number	PCS
1	Electrical plug	P113576E	1

JOINING KIT

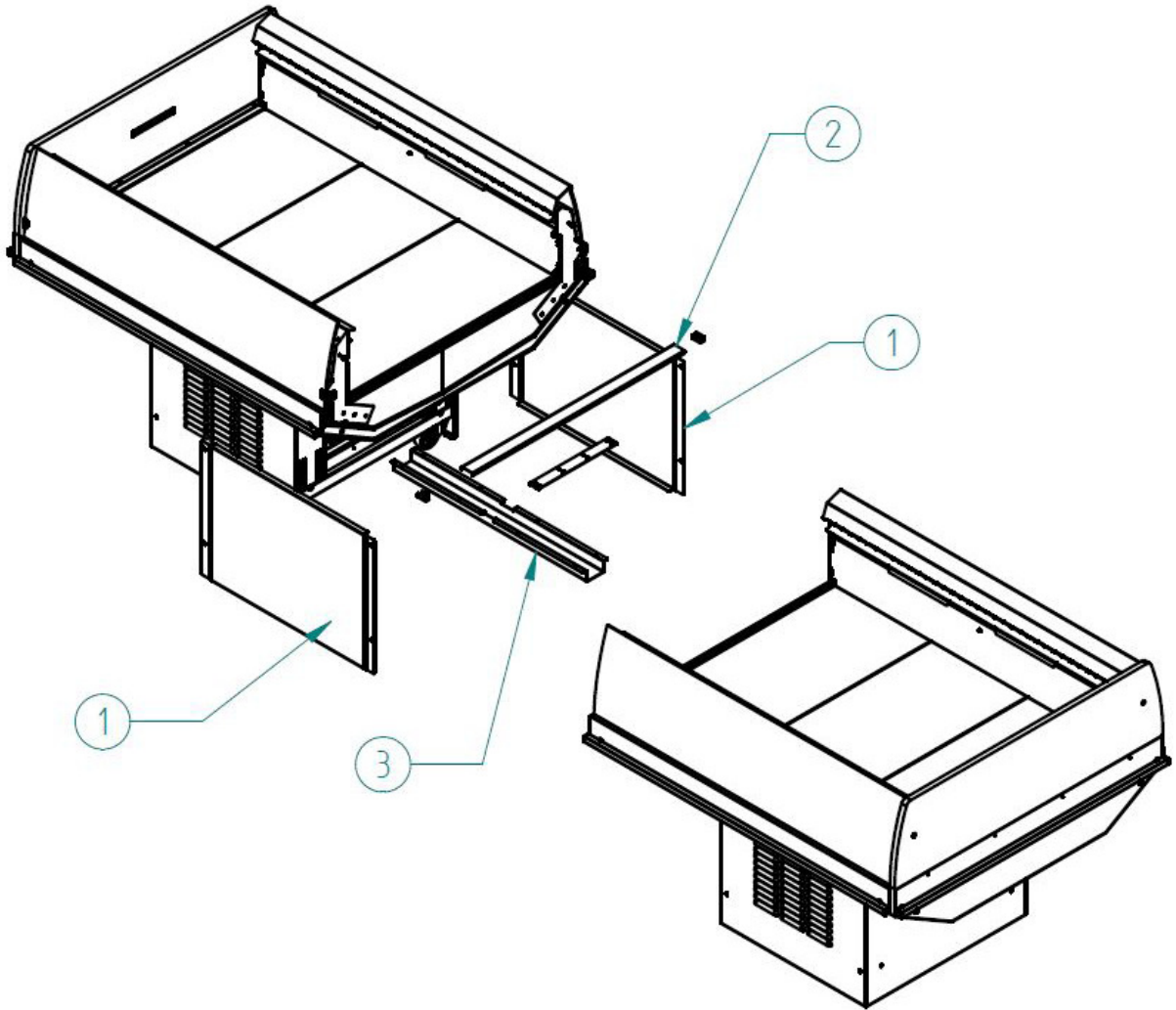

#	DESCRIPTION	Part Number	PCS
1	Front-Rear close panel INOX	P113577C	2
2	Joining kit	P113578A	1
3	Cables profile	P113579K	1

PARTS INDEX MIDA-3x3

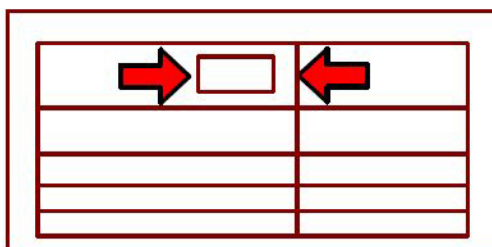
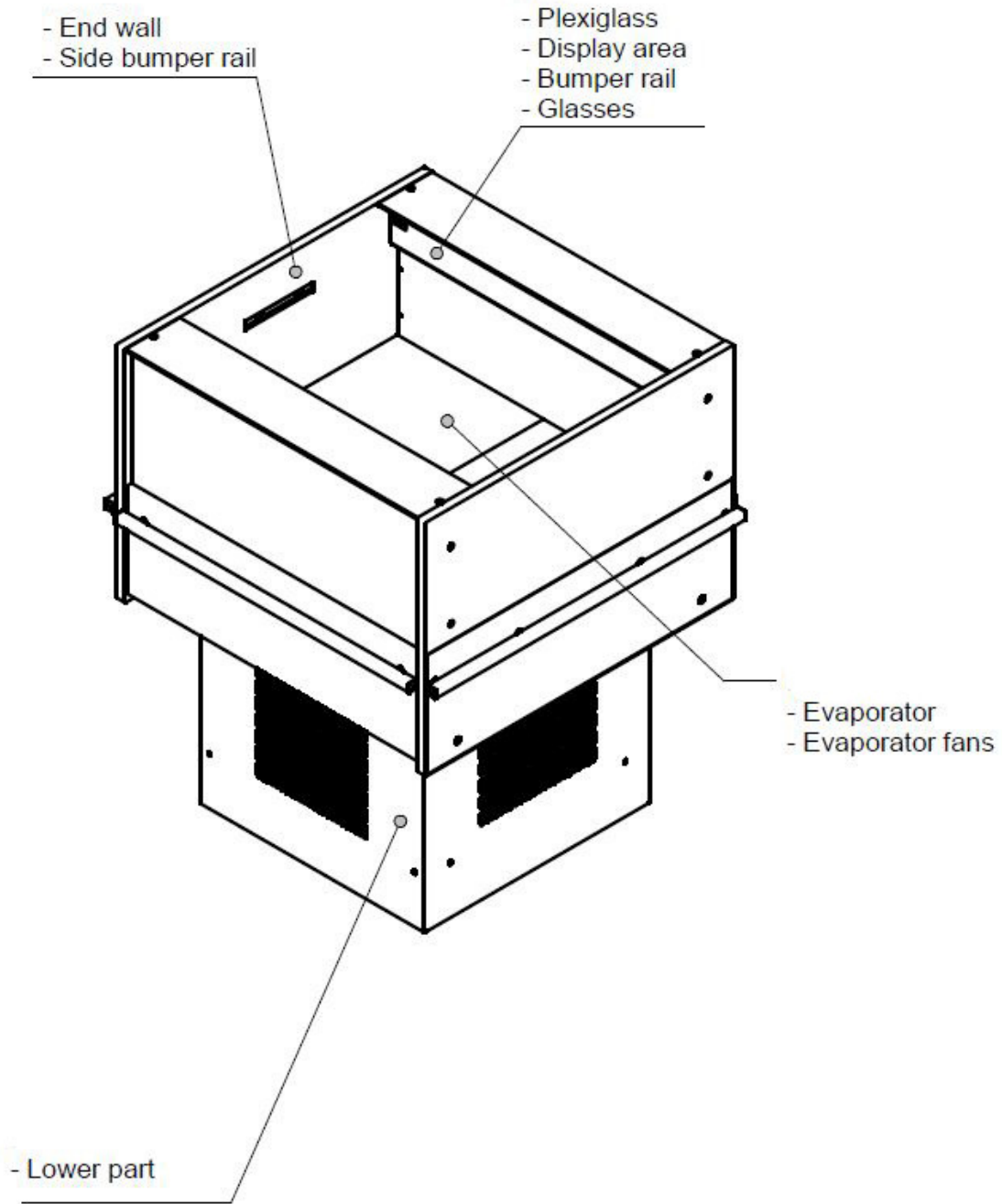

Provide the following information about the part you are ordering:

- Model number and serial number* of the case for which the part is intended.
- Length of the part (if applicable).
- Color of part (if painted) or color of polymer part.
- Whether part is for left or right-hand application.
- Quantity

END WALLS / SIDE BUMPER

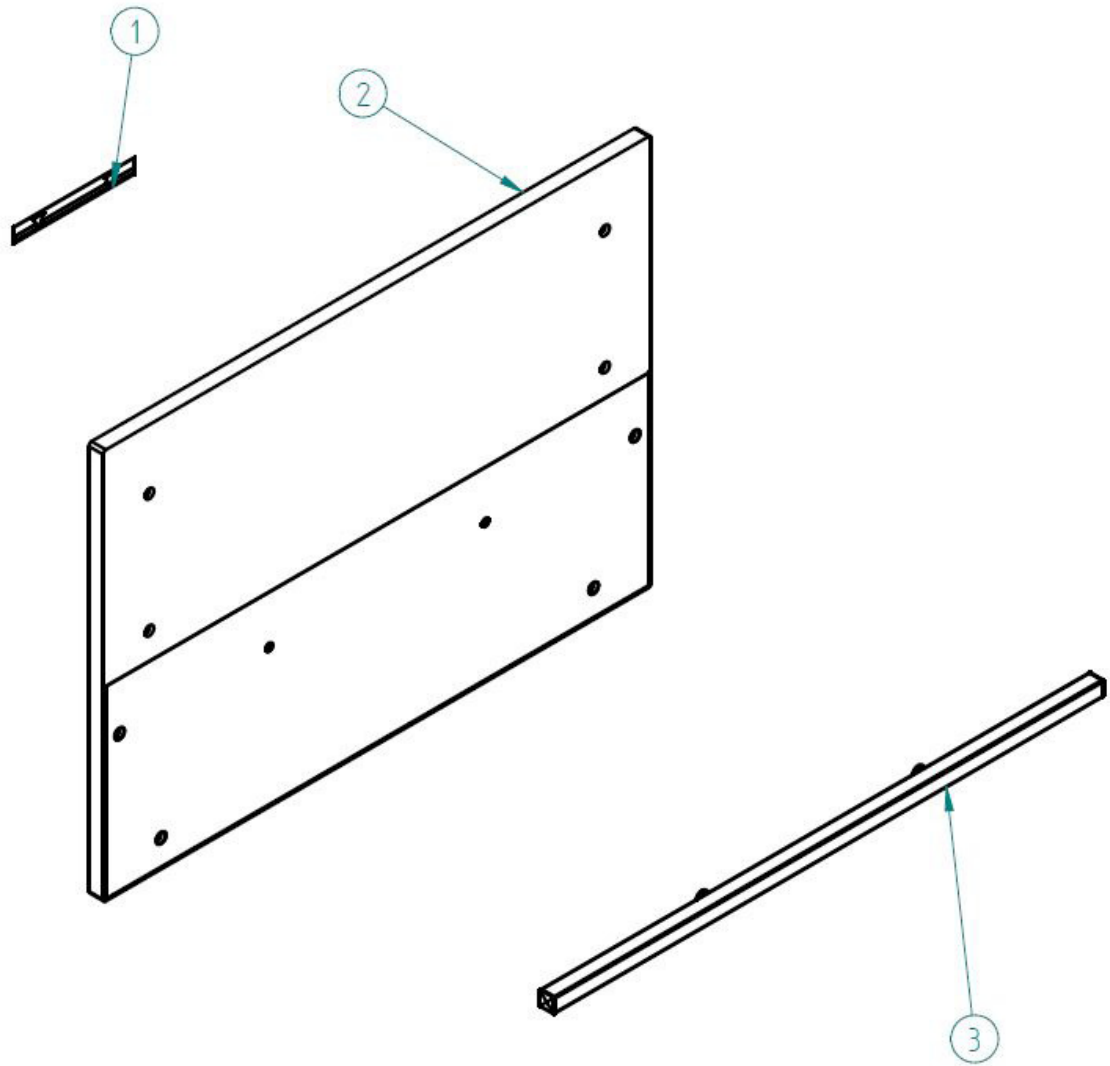

#	DESCRIPTION	Part #	PCS
1	Label "Load limit line"	P114171B	1
2	Plexiglass end wall	P114172M	1
3	End wall bumper rail kit	P114173H	1

PARTS LIST

PLEXIGLASS/BUMPER RAIL / DISPLAY AREA

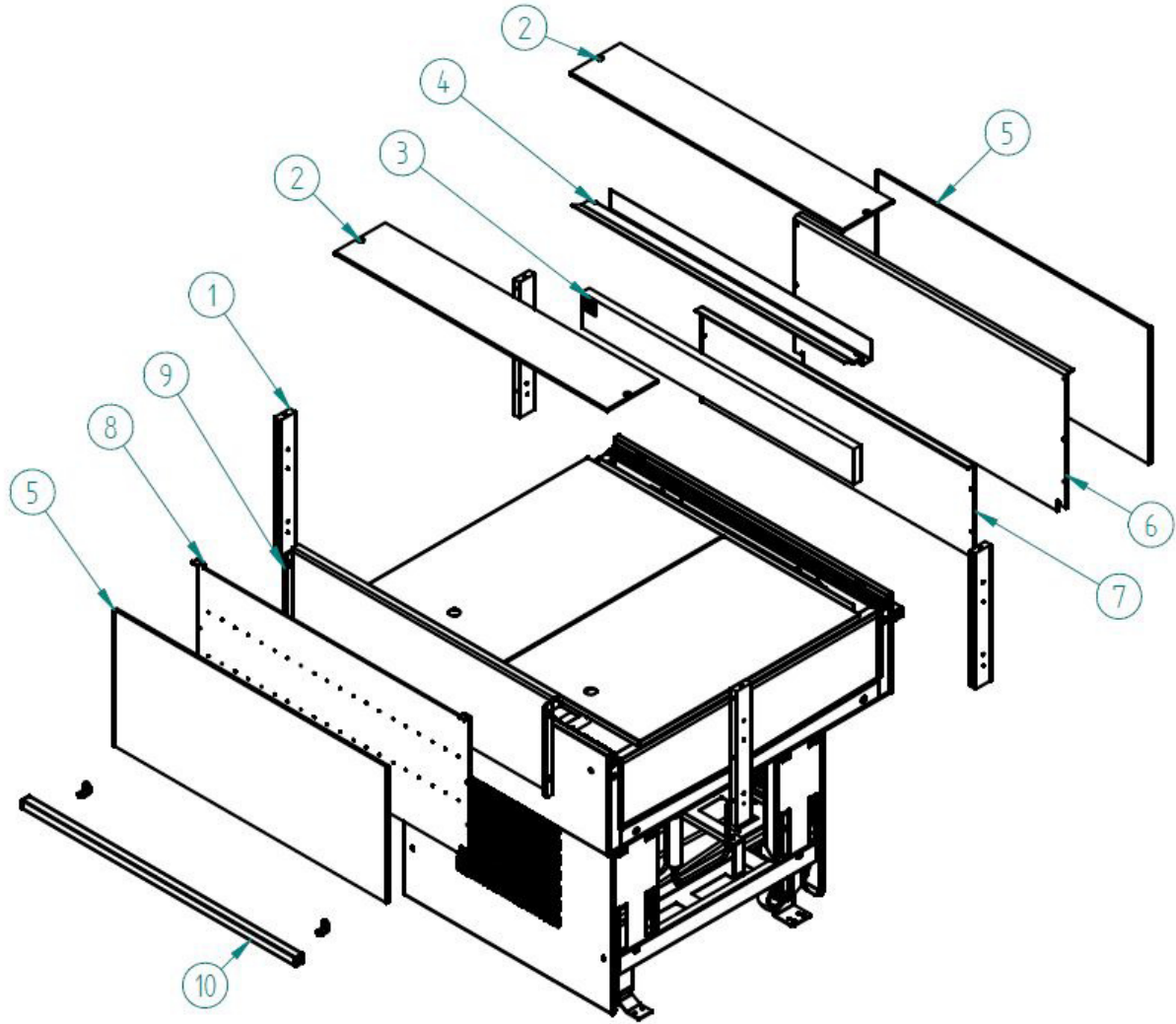

#	DESCRIPTION	Part Number	PCS
1	Air Inlet End Wall DX/SX	P114146E	4
2	Plexi Worktop	P114147C	2
3	Honeycomb	P114148A	1
4	Honeycomb Holder	P114149K	1
5	Front/ Rear Glass	P114150F	2
6	Rear Closed Air Inlet	P114151D	1
7	Product Holder	P114152B	1
8	Front Holed Air Inlet	P114153M	1
9	Front Air Inlet	P114154H	1
10	Front and Back Bumper Rail Kit	P114155F	2

EVAPORATOR / EVAPORATOR FANS

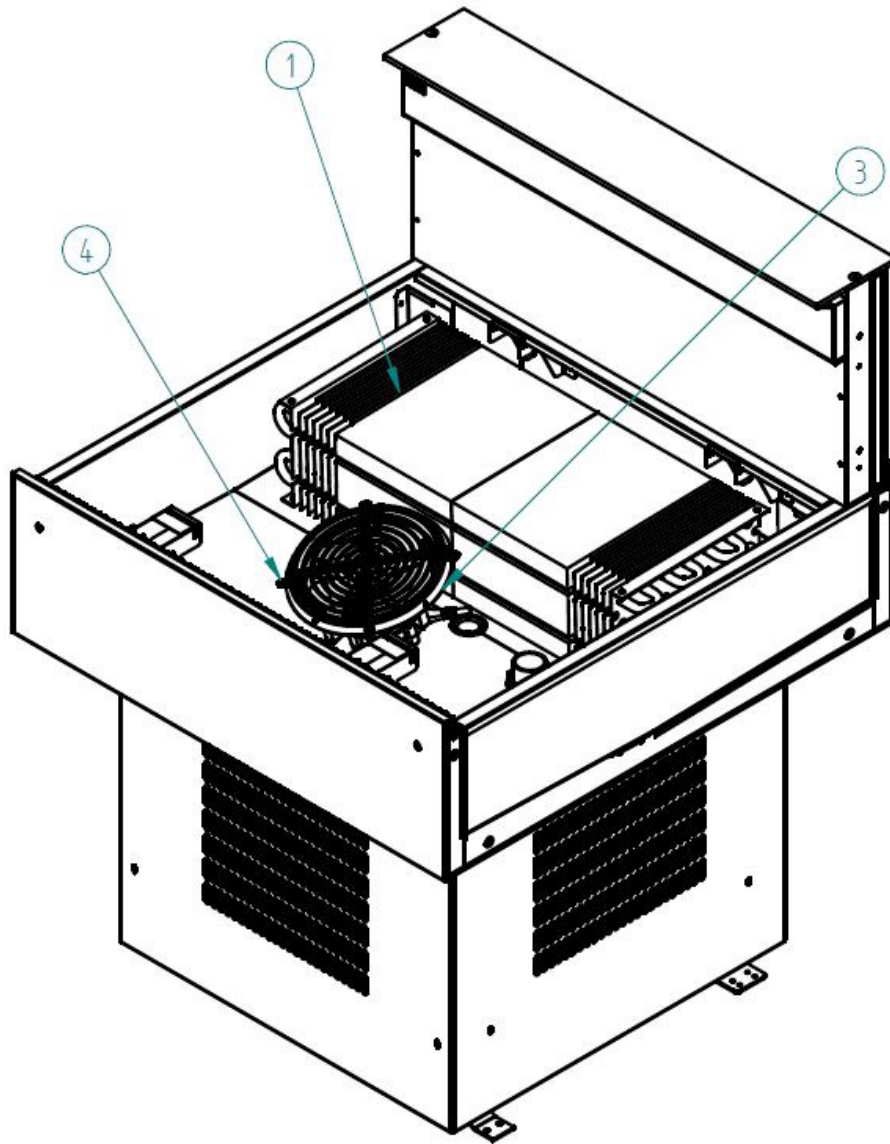

#	DESCRIPTION	Part Number	PCS
1	Evaporator R290	P114156D	1
2	Evaporator Fan Complete with Impeller and Metal Ring	P114157B	1
3	Protective Metal Grid For Evaporator Fan	P114158M	1

PARTS LIST

Lower Parts

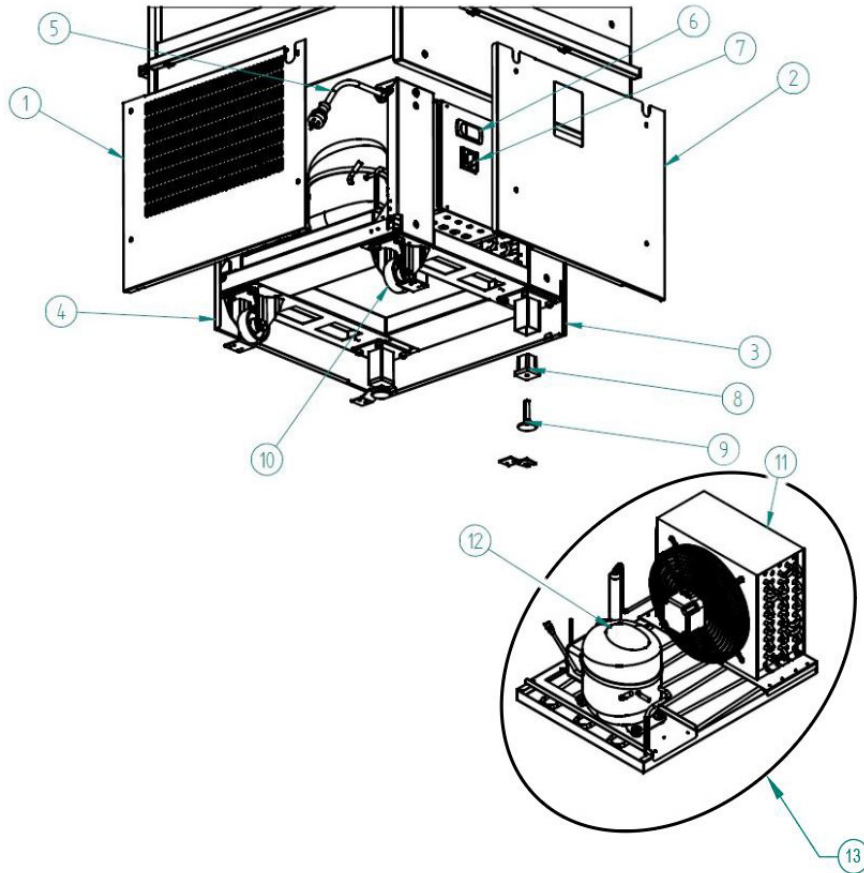

#	DESCRIPTION	Part Number	PCS
1	Rear Base Panel	P114159H	1
2	Left Side Base Panel	P114160E	1
3	Front Base Panel	P114161C	1
4	Right Side Base Panel	P114162A	1
5	Electrical Plug	P114163K	1
6	Carel Thermostat PJEXCOH100	P114164G	1
7	On/Off Switch	P114165E	1
8	Adjustable Feet Support	P114166C	1
9	Adjustable Feet TH40	P114167A	1
10	Support Wheel	P114168K	1
11	Condensing Fan Motor	P114169G	1
12	Compressor EMI90UEX R290	P114170D	1
13	Condensing Unit SP 0905.083A	P115686M	1

Electrical Diagram: MIDA-3

T01 = Compressor
 M01 = Condenser Fan
 M02 = Evaporator Fan
 R01/02 = Heating Wire
 T02 = Transformer
 S01 = Switch
 sd01 = Temperature Probe

sd02 = Defrost Probe
 K01 = Contactor
 E01 = Temperature Controller
 A01 = Variable Speed Drive Control 0-10Vdc
 A02 = Variable Speed Drive Control 0-10Vdc

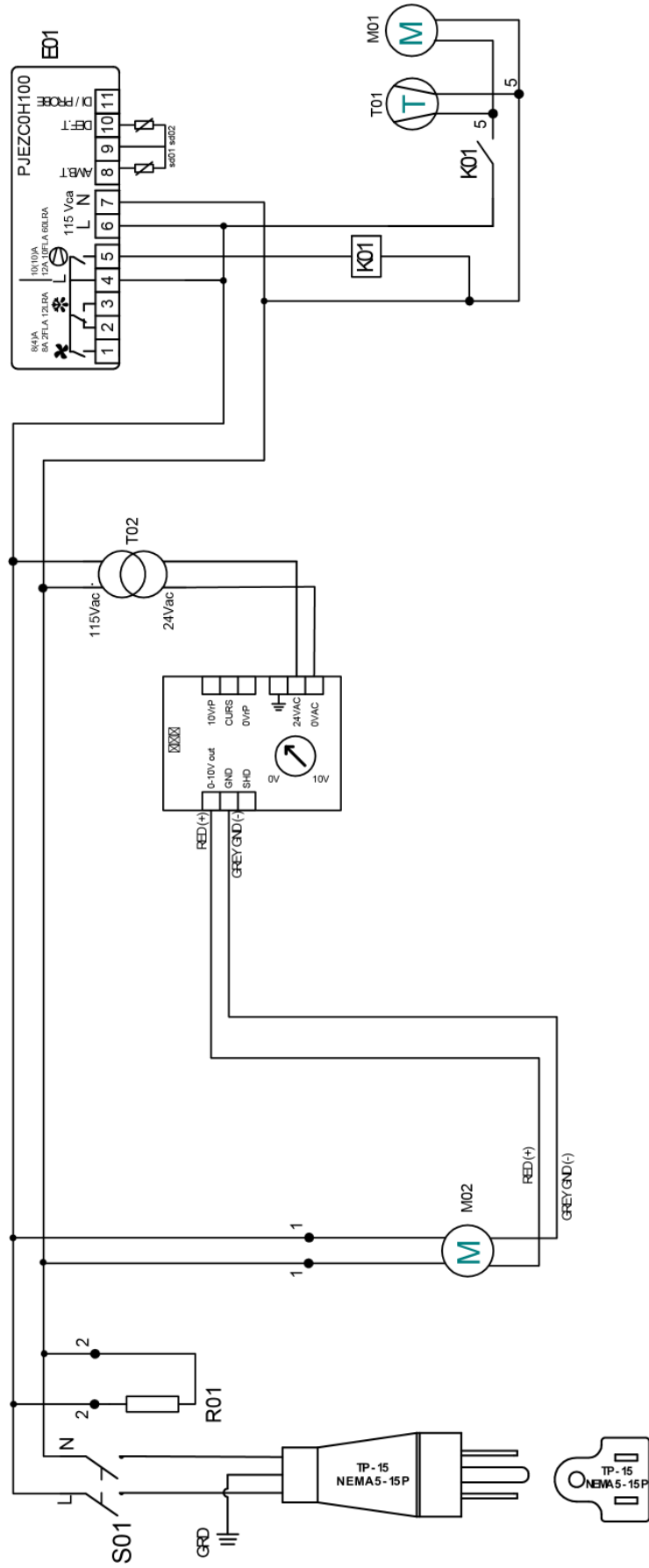

Electrical Diagram: MIDA-4

T01 = Compressor
 M01 = Condenser Fan
 M02 = Evaporator Fan
 R01/R02 = Heating Wire
 T02 = Temperature Controller
 S01 = Switch
 sd01 = Temperature Probe
 sd02 = Defrost Probe
 K01 = Contactor
 K02 = Contactor
 E01 = Temperature Controller
 A01 = Variable Speed Drive Control 0-10Vdc
 A02 = Variable Speed Drive Control 0-10Vdc

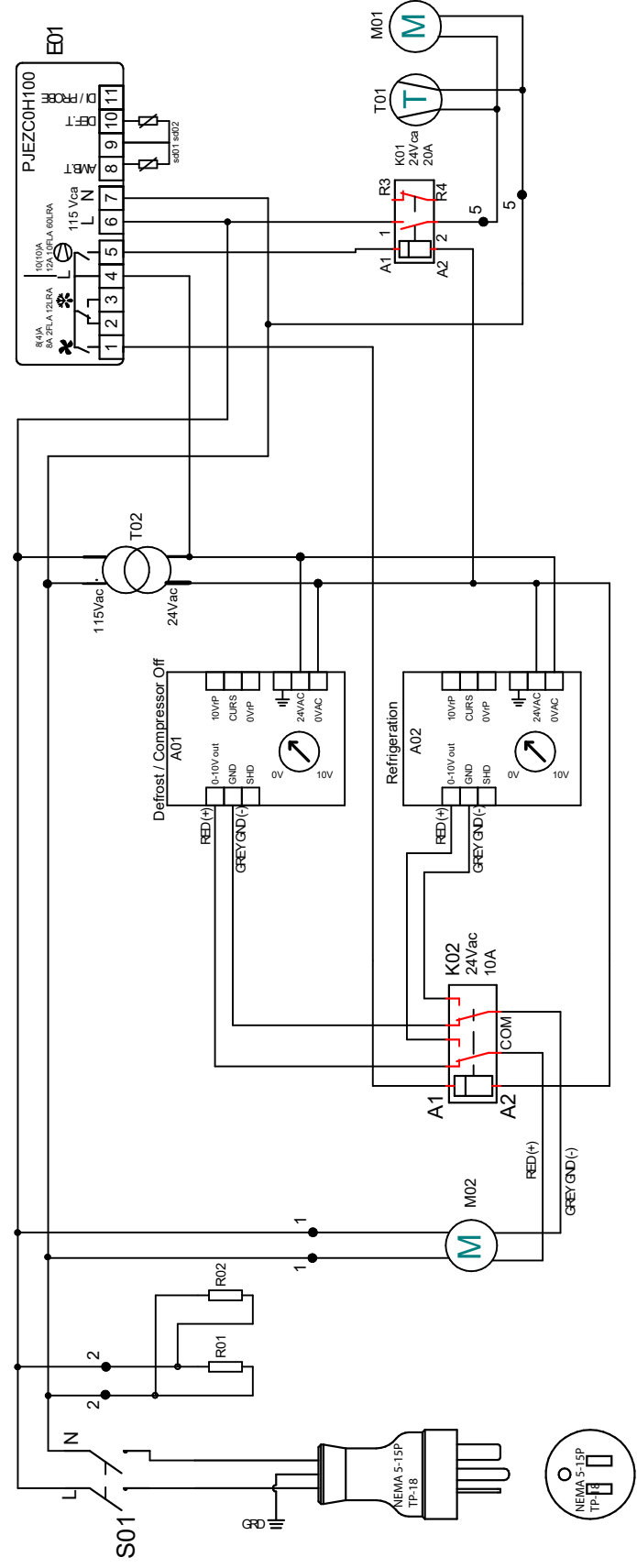

19-00544-01C01

MIDA-4X8 WIRING DIAGRAM

Electrical Diagram: MIDA-8

- | | |
|--------------------------|--|
| T01 = Compressor | sd02 = Defrost Probe |
| M01 = Condenser Fan | SSR1/SSR2 = Contactor |
| M02 = Condenser Fan | K01 = Contactor |
| M03 = Evaporator Fan | E01 = Temperature Controller |
| M04 = Evaporator Fan | A01 = Variable Speed Drive Control 0-10Vdc |
| R01/02 = Heating Wire | A02 = Variable Speed Drive Control 0-10Vdc |
| T02 = Transformer | |
| S01 = Switch | |
| sd01 = Temperature Probe | |

ELECTRICAL PANEL UNIT 1

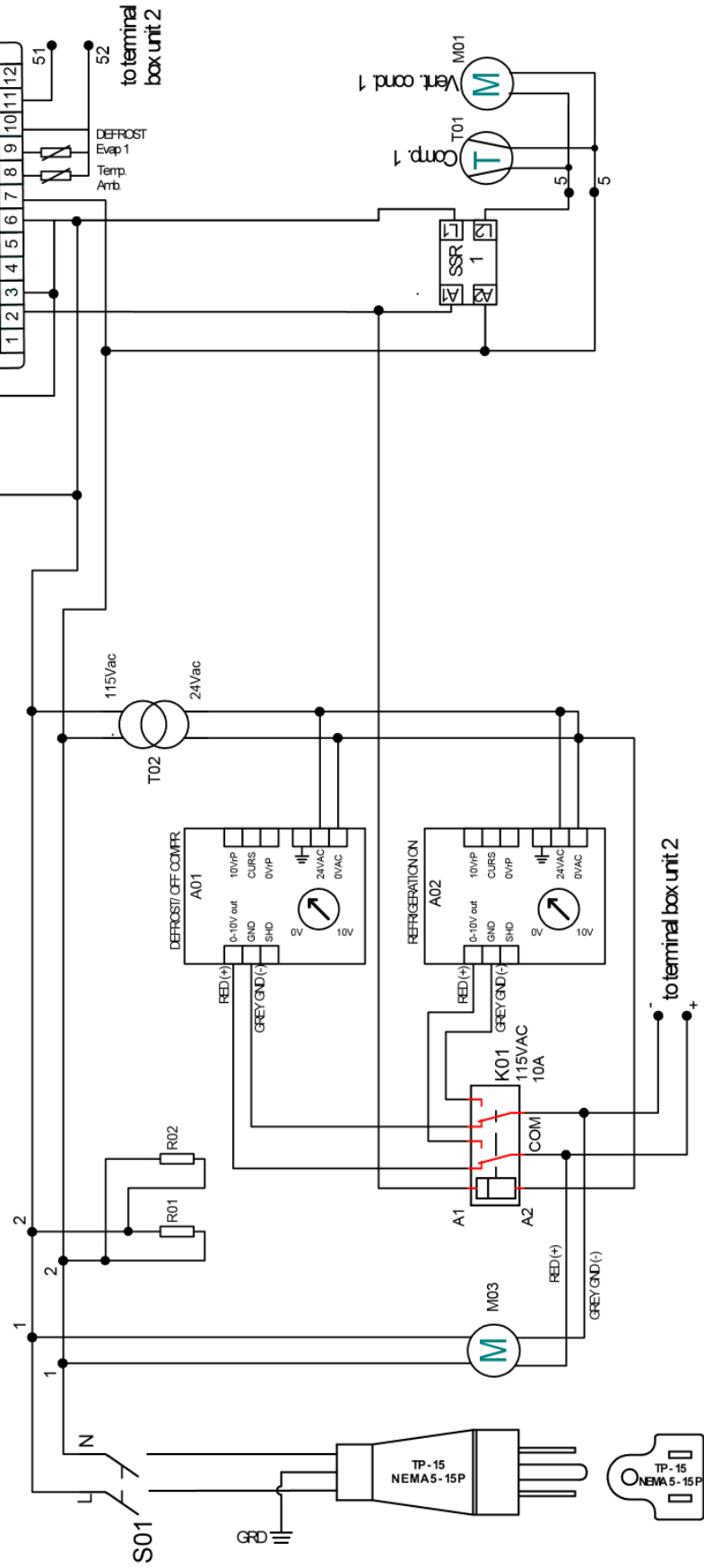

Electrical Diagram: MIDA-8

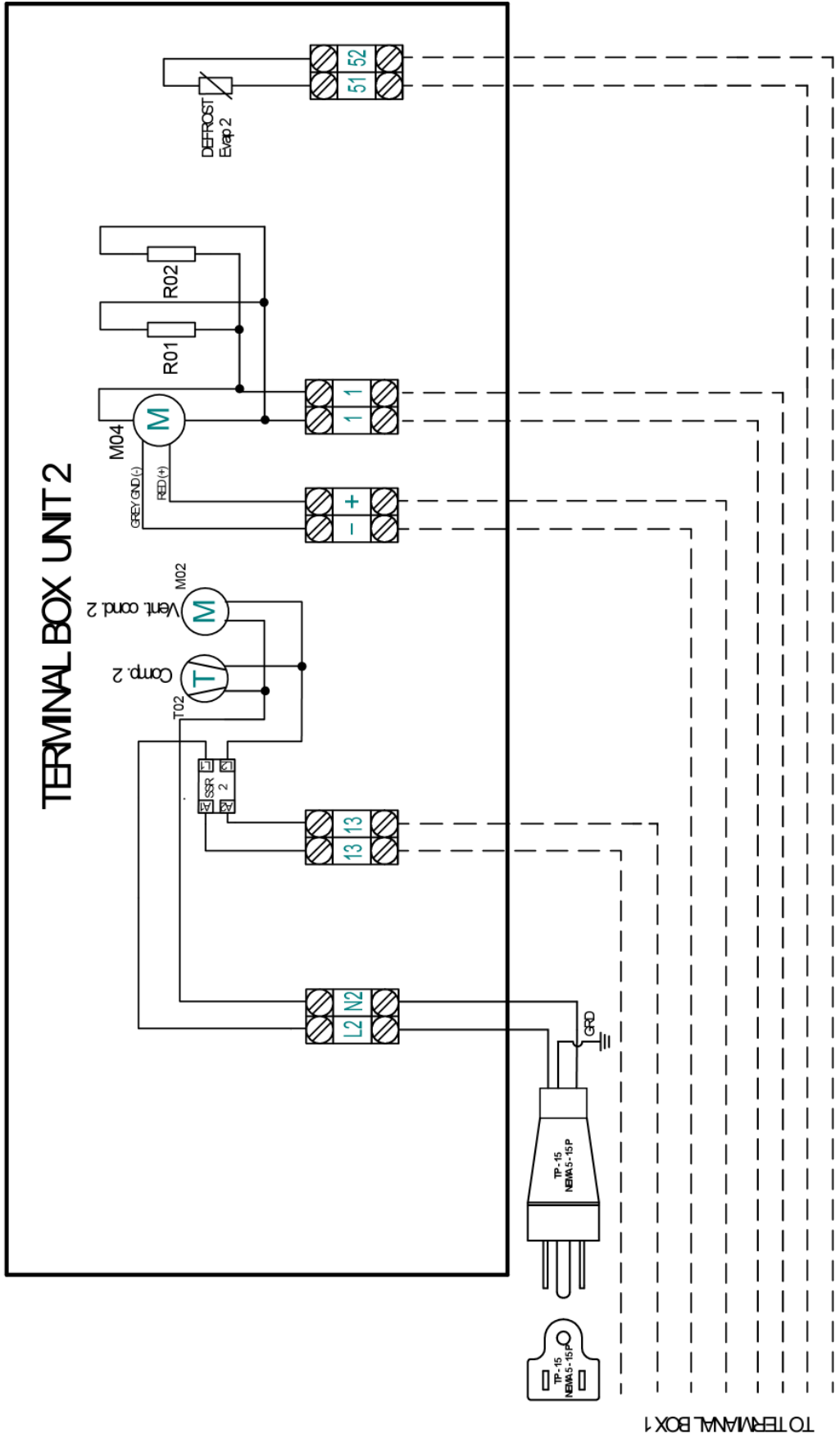

Warning **Maintenance & Case Care**

When cleaning cases the following must be performed PRIOR to cleaning:

To avoid electrical shock, be sure all electric power is turned off before cleaning. In some installations, more than one switch may have to be turned off to completely de-energize the case.

Do not spray cleaning solution or water directly on fan motors or any electrical connections.

All lighting receptacles must be dried off prior to insertion and re-energizing the lighting circuit.

Please refer to the Use and Maintenance section of this installation manual.

Hillphoenix[®]

A  **DOVER** COMPANY

Tel: 1-800-283-1109

1925 Ruffin Mill Rd, Colonial Heights, VA 23834

Due to our commitment to continuous improvement, all specifications are subject to change without notice.

Hillphoenix is a Sustaining Member of the American Society of Quality.

Visit our website at www.hillphoenix.com





A DOVER COMPANY

Hill PHOENIX, Inc.
Hereinafter Referred To As Manufacturer

LIMITED WARRANTY

GENERAL WARRANTY

Manufacturer's products are warranted to be free from defects in materials and workmanship under normal use and maintenance for fourteen months from date of shipment from manufacturer (the "Base Warranty Period"). In the event of a qualifying warranty claim, a new or rebuilt part to replace any defective part will be provided without charge. The replacement part is covered under this warranty for the remainder of the applicable Base Warranty Period. In order to be eligible for warranty coverage, customer must: (i) notify Manufacturer promptly upon discovery of a warrant defect, and (ii) comply with the warranty claim procedures provided by Manufacturer from time to time.

This equipment warranty does not include labor or other costs incurred for diagnosing, repairing, removing, installing, shipping, servicing, or handling of either defective parts or replacement parts.

The warranty shall not apply:

1. To any unit or any part thereof which has been subject to accident, alteration, negligence, misuse or abuse, or which has not been operated in accordance with the manufacturer's recommendations, or in conditions outside of Manufacturer's specifications, or if the serial number of the unit has been altered, defaced, or removed.
2. When the unit, or any part thereof, is damaged by fire, flood, or other act of God.
3. To products that are impaired or damaged due to improper installation.
4. When installation and startup forms are not properly completed or returned within two weeks after startup.
5. If the defective part is not returned to the Manufacturer.
6. To service, maintenance or wear and tear parts (such as lights, starters and ballasts)

MODIFICATIONS TO GENERAL WARRANTY

The following sets forth certain modifications to the General Warranty for specific products of Manufacturer:

DISPLAY CASE AND SPECIALTY PRODUCTS CLEARVOYANT® LED LIGHTING

The warranty period for Clearvoyant LED lighting components within the Clearvoyant lighting system is five years from date of shipment.

REMEDY LIMITATION/DAMAGES EXCLUSION

THE REMEDY OF REPAIR OR PROVISION OF A REPLACEMENT PART WITHOUT CHARGE SHALL BE THE EXCLUSIVE REMEDY FOR ANY WARRANTY CLAIM HEREUNDER. WITHOUT LIMITING THE FOREGOING, MANUFACTURER SHALL NOT BE LIABLE UNDER ANY CIRCUMSTANCES FOR INCIDENTAL, INDIRECT OR CONSEQUENTIAL DAMAGES, INCLUDING LOSS OF PROFIT, LABOR COST, LOSS OF REFRIGERANT OR FOOD PRODUCTS.

EXCLUSIVE WARRANTY

THE FOREGOING WARRANTY IS THE EXCLUSIVE WARRANTY WITH RESPECT TO THE PRODUCTS. ALL OTHER WARRANTIES, WHETHER EXPRESS OR IMPLIED, INCLUDING WITHOUT LIMITATION, THE WARRANTIES OF MERCHANTABILITY OR FITNESS FOR A PARTICULAR PURPOSE, ARE HEREBY DISCLAIMED AND EXCLUDED. NO IMPLIED WARRANTY SHALL BE DEEMED CREATED BY COURSE OF DEALING OR USAGE OF TRADE. NO OTHER PERSON IS AUTHORIZED TO EXPAND OR CREATE ANY OBLIGATION GREATER THAN OR MORE EXPANSIVE THAN THE WARRANTY PROVIDED HEREIN.

Submit warranty claims to:

833-280-5714

Choose option for Warranty or Tech Support

Select Division Per Menu list

<https://www.hillphoenix.com/warrantyauthorization-procedure/>

Select Warranty Request Form (5th image)