

Like the NMGHPA, the deep-well NHMGHP allows quick and easy selection of products. This high performance low-profile meat merchandiser has an additional 3" of merchandising depth over the comparable NMGHPA, for efficient presentation of fresh meat, dairy and deli, and critical temperature produce.



**High Performance TC Coil™**

High Performance (HP) Merchandisers feature our patented TC Coil™ design, which represents a major technology breakthrough for the commercial refrigeration industry. Developed jointly by Carrier Corporation and Tyler, the TC Coil enables HP merchandisers to operate more efficiently, providing energy savings that allow faster payback periods for food retailers.

**Note:** For more information about Tyler high performance display merchandisers featuring TC Coil, go to the Technologies section of this catalog on page 8.

**Features & Benefits**

- Energy-efficient copper tube and aluminum fin coils.
- 6" angled clear front glass to enhance product visibility.
- Adjustable white powder-coated display screens enhance product presentation.
- Solid steel base adds strength and durability.
- Easily removable interior components for quicker cleaning.
- Fan assembly design allows access to coil and drain pan.
- Off-cycle defrost.

**Options**

- ECM fan motors for additional energy savings.

Specifications are subject to engineering changes without notice.

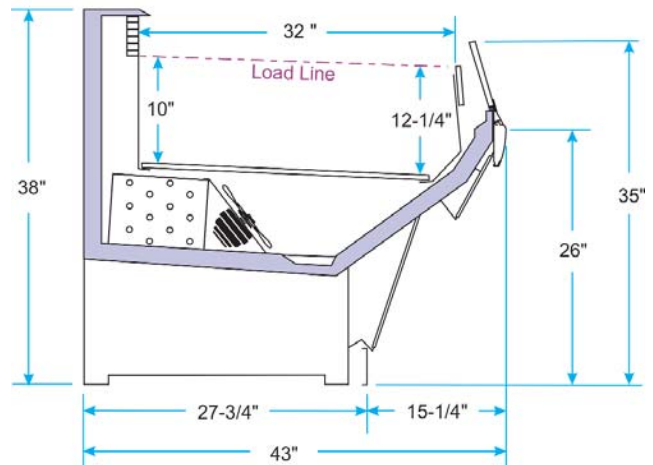

Model	Case Length	Description	Capacity in Cubic Feet
NHMGHP	6' • 8' • 12'	Glass Front, TC Coil	14.9 • 19.8 • 29.7

