

N2PSSC Mobile Bulk Produce



The N2PSSC bulk produce merchandiser has its own self-contained refrigeration system and swivel caster wheels for flexible, on-the-spot mobile product presentations.

Features & Benefits

- ◆ Self-contained refrigeration system with R404A refrigerant. 1/2 HP condensing unit and evaporative condensate pan provides all refrigeration and drainage for the case.
- ◆ Telescoping white powder-coated display screens enhance product presentation.
- ◆ Four swivel caster wheels provide easy mobility. Two wheel-locks provide stability when in a rested position.
- ◆ Fan assembly design allows access to coil and drain in bottom of case.
- ◆ Off-cycle defrost.
- ◆ 7-7/16" top shelf adds merchandising flexibility.

Options

- ◆ ECM fan motors for additional energy savings.
- ◆ Light bar attaches to top for increased product illumination.
- ◆ Multiple-depth shelving alternatives.
- ◆ 12' produce hose assembly.
- ◆ Rear panel overlay comes in 3 finishes; stainless steel, painted steel and simulated woodgrain..

Specifications are subject to engineering changes without notice.

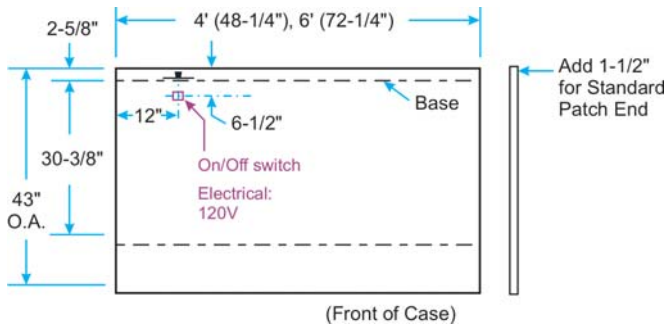
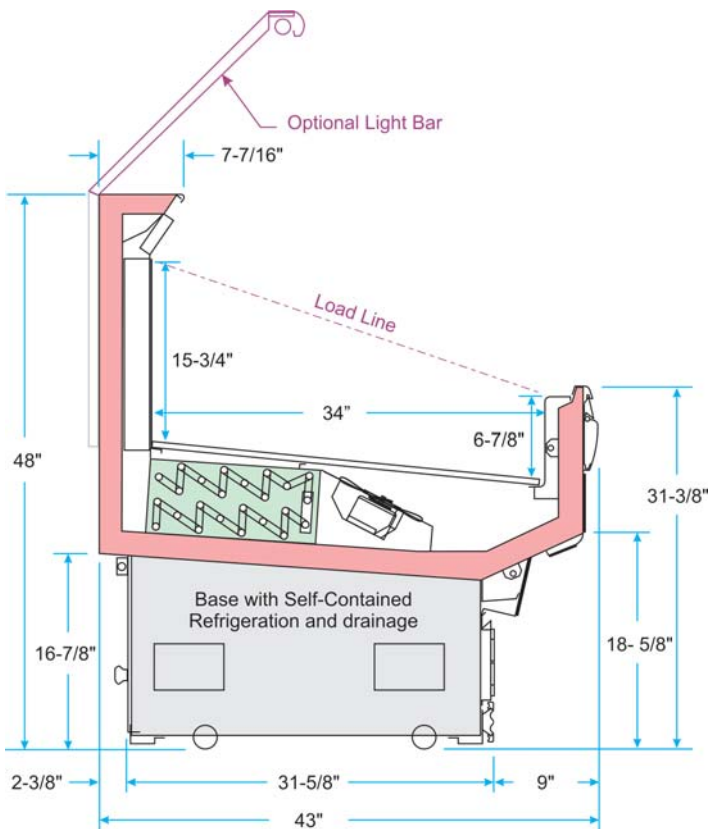

Model	Case Length	Description	Capacity in Cubic Feet
N2PSSC	4' • 6'	Self-Contained Bulk Produce, standard coil	10.8 • 16.0

Self-Contained Refrigeration Access



Opening the rear panel allows access to coil area, electrical controls and refrigeration controls.



Opening the front panel allows access to the condensate evaporation system.

Optional Accessories



Light Bar



12' Produce Hose Assembly